



Linea Color 2K and 4K GigE Vision

Color CMOS Line Scan Cameras

High Performance Color GigE Camera with TurboDrive



The new Linea Color™ line scan cameras deliver the exceptional performance and features found in Teledyne DALSA's current lineup of high-end cameras at an unprecedented price point.

Based on bilinear color CMOS technology, the Linea Color GigE cameras has a 2k or 4k 7.04 μm x 7.04 μm pixel array. With excellent sensitivity and speed, Linea Color surpasses the requirements of demanding applications—such as food sorting, materials grading, web inspection, and general purpose machine vision.

The Linea Color cameras come complete with many attractive features, including configurable GPIO ports, Burst Mode and Meta Data per each line. The GigE models provide multiple ROI and AOI, and multiple user and calibration coefficients sets for various lighting conditions.

Our proprietary, patent pending, TurboDrive™ technology delivers high speed data transfer capability that breaks through the GigE limit. Depending on the application, speeds up to 45 kHz are achievable, as TurboDrive boosts data transfer speeds 2 or 3 times faster than standard GigE Vision™ speeds – with no loss of image quality.

Key Features

- Low cost
- Burst mode
- Compact
- Meta data per each line

Programmability

- Multiple regions of interest and areas of interest for calibration and data reduction
- 8 bit output
- Smart flat field and lens shading correction
- 4 programmable coefficient sets
- Configurable GPIO ports, timers and counters

Typical Applications

- Automated optical inspection
- High performance sorting systems
- Materials grading
- Web inspection
- General purpose machine vision

Regulatory Compliance

- CE, FCC and RoHS

Specifications

Resolution	2048 x 2 or 4096 x 2
Line Rate	26 kHz, maximum—2k models without TurboDrive 13 kHz, maximum—4k models without TurboDrive (45 kHz, maximum—both models with TurboDrive)
Pixel Size	7.04 μm x 7.04 μm
Data Format	8 bit
Output	Gigabit Ethernet
Lens Mount	M42 x 1, C and F-mount adapters available
Responsivity	See graph
Dynamic Range	> 60 dB
Nominal Gain Range	10x
Size	62 mm x 62 mm x 46.64 mm
Mass	< 280 g
Operating Temp	0 °C to 65 °C (front plate)
Power	+12 V to +24 V DC, HD15 connector (shared with I / O)
Power Dissipation	< 8 W
I / O	HD15 connector
Software Platform	GigE Vision v1.2 compliant Teledyne DALSA Sopera LT or 3rd party GenICam™ compliant SDK

Part Number	Models		
	Resolution	Maximum Line Rates	Pixel Size
LA-GC-02K05B-00-R	2048 x 2	26 kHz without TurboDrive (45 kHz with TurboDrive)	7.04 μm x 7.04 μm
LA-GC-04K05B-00-R	4096 x 2	13 kHz without TurboDrive (45 kHz with TurboDrive)	7.04 μm x 7.04 μm



Linea Color 2K and 4K GigE Vision

CMOS Line Scan Cameras

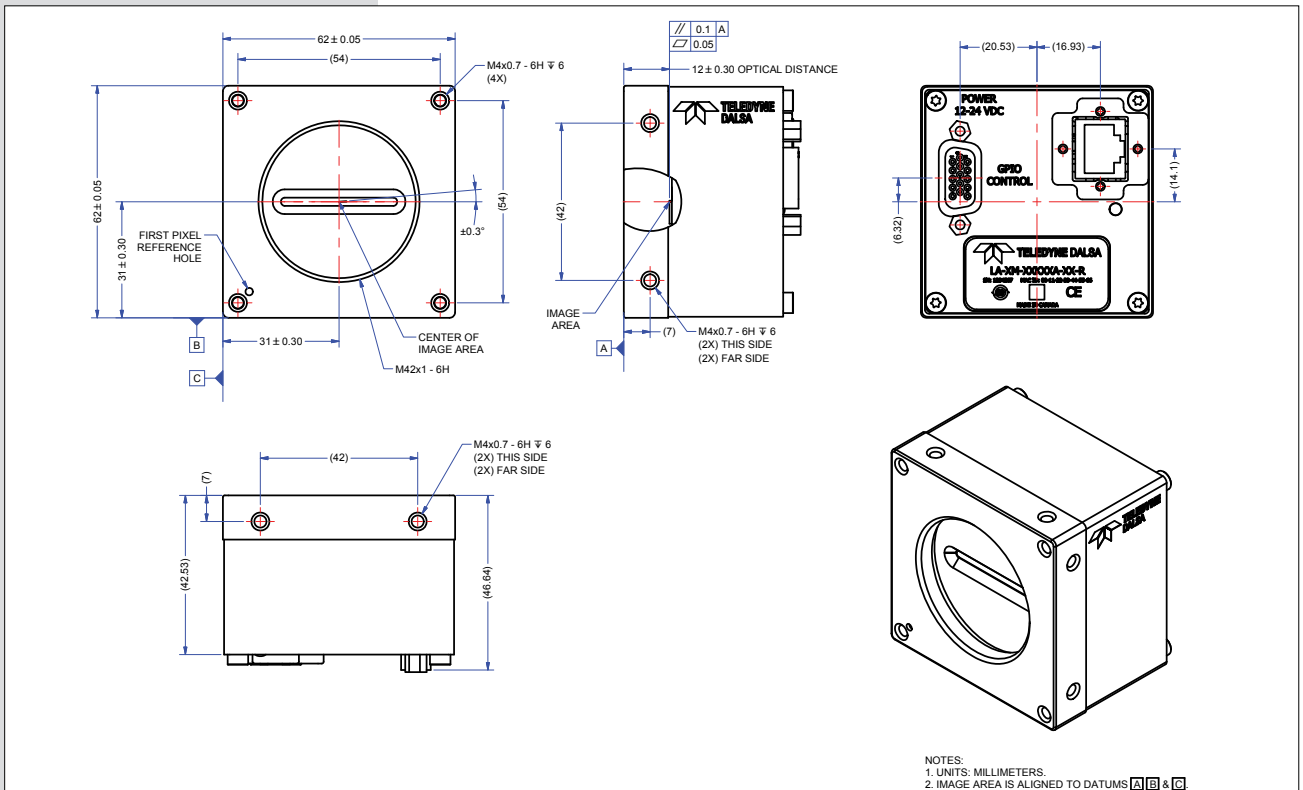
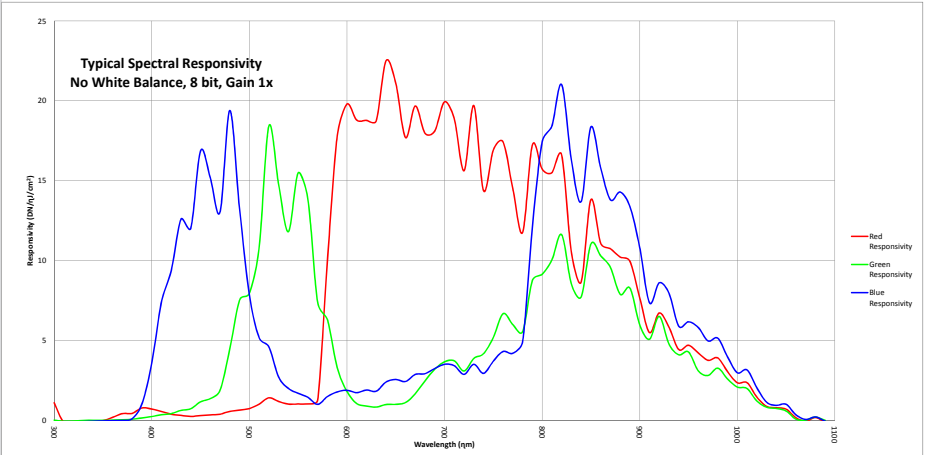

www.teledynedalsa.com

Americas
Boston, USA
+1 978-670-2000
sales.americas@teledynedalsa.com

Europe
Krailling, Germany
+49 89-89-54-57-3-80
sales.europe@teledynedalsa.com

Asia Pacific
Tokyo, Japan
+81 3-5960-6353
sales.asia@teledynedalsa.com

Shanghai, China
+86 21-6427-9081
sales.asia@teledynedalsa.com

Teledyne DALSA has its corporate offices in Waterloo, Canada
Teledyne DALSA reserves the right to make changes at any time without notice. Teledyne DALSA © 2016.
Revision number 03-070-20093-02. Revision date October 31, 2016.

