



Linea™ ML Trilinear

8k and 16k Color CMOS Camera



Key Features

- » High speed: up to 300 kHz line rate
- » Three native colors (RGB)
- » Bi-directional
- » Independent exposure control per line (start and end of exposure)
- » Long fiber optic cable
- » Horizontal parallax correction
- » LUT for gamma correction
- » Low system cost

Programmability

- » Multiple regions and areas of interest
- » Flat field and lens shading correction
- » High speed loading of coefficient sets
- » GenICam™ compliant interface

Typical Applications

- » Printing inspection
- » Flat panel inspection
- » Electronics inspection
- » Web inspection
- » General purpose machine vision

High-Speed Color Camera with a Fiber Optic Interface

The Linea™ ML trilinear CMOS 8K and 16K color cameras exceed the requirements of demanding color imaging applications with industry leading performance. Based on Teledyne DALSA's unique CMOS line scan technology, the Linea ML trilinear cameras deliver superb color in a compact footprint with a high-speed fiber-optic interface.

Specifications

Resolution	8,192 x 3 pixels (8K) 6,384 x 3 pixels (16K)
Line Rate	100/47 kHz x 3 maximum
Pixel Size	5 μm x 5 μm
Data Format	8-bit
Output	RGB color
Lens Mount	M58 x 0.75 (8K) M90 x 1 (16K)
Responsivity	See graph
Dynamic Range	> 60 dB
Nominal Gain Range	1x to 10x
Size	76 mm x 76 mm x 85 mm (8K) 97 mm x 140.5 mm x 78.6 mm (16K)
Mass	< 500 g (8K) 1.2 kg (16K)
Operating Temp	0 °C to +65 °C (front plate)
Power	+12 V to +24 V DC, Hirose 12-pin
Power Dissipation	16 W (8K) 28/21 W (16K)
Control & Data	Camera Link HS, LC (8K) or CX4/LC (16K)
GPIO	Direction and independent line control
Regulatory Compliance	CE, FCC, and RoHS

Camera Model

Part Number	Resolution	Max. Line Rates	Pixel Size	Output
ML-FC-08K10T-00-R	8,192 x 3 pixels	280 kHz (93 kHz x 3) / 300 kHz using AOI	5 μm x 5 μm	RGB
ML-HC-16K10T-00-R	16,384 x 3 pixels	300 kHz (100 kHz x 3)	5 μm x 5 μm	RGB
ML-FC-16K04T-00-R	16,384 x 3 pixels	47 kHz x 3	5 μm x 5 μm	RGB

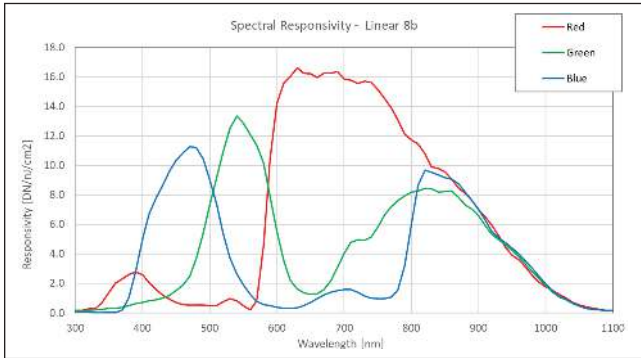

8k Model

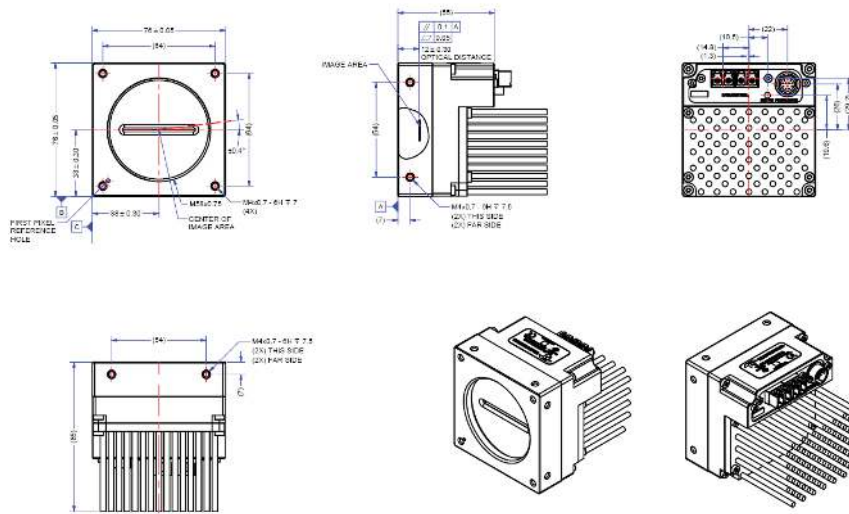

NOTES:
1. UNITS: MILLIMETERS
2. IMAGE AREA IS ALLIGNED TO DATUMS ① ② ③ ④

16k Model

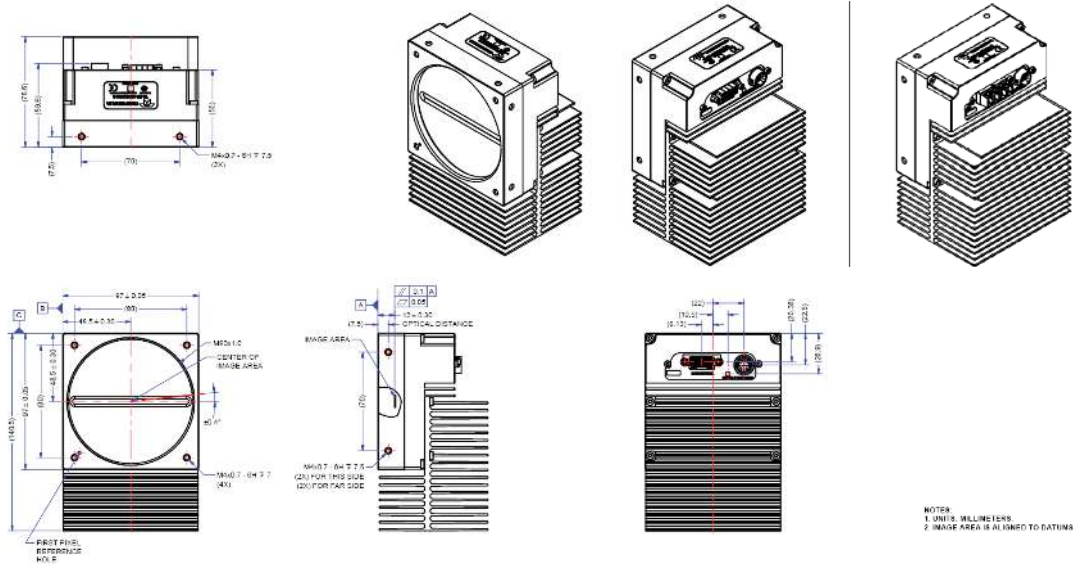

NOTES:
1. UNITS: MILLIMETERS
2. IMAGE AREA IS ALLIGNED TO DATUMS ① ② ③ ④

Americas

Boston, USA
+1 978-670-2000
sales.americas@teledynedalsa.com

Europe

Krailling, Germany
+49 89-89-54-57-3-80
sales.europe@teledynedalsa.com

Asia Pacific

Tokyo, Japan
+81 3-5960-6353
sales.asia@teledynedalsa.com

Shanghai, China
+86 21-3368-0027
sales.asia@teledynedalsa.com