

PhoXi 3D Scanner

User Manual and Installation Instructions

Thank you for choosing Photoneo® PhoXi® 3D Scanner. Please take a few minutes to read this manual and become familiar with the device.

For more information on our products, accessories, replacement parts, software and services, see our website www.photoneo.com/phoxi-3d-scanner/ or contact our team at support@photoneo.com.

Legal Information

Warning Notice System

This manual contains notices that should be observed in order to ensure personal safety, as well as prevent damage to equipment. The notices referring to personal safety are highlighted with a safety alert symbol, while notices referring only to equipment do not have a safety alert symbol. The notices are graded according to the degree of danger.

⚠ WARNING

Indicates that death or severe personal injury may result if proper precautions are not taken.

⚠ CAUTION

When a safety alert symbol is shown, it indicates that minor personal injury can result if proper precautions are not taken.

CAUTION

When no safety alert symbol is shown, it indicates that equipment damage can result if proper precautions are not taken.

NOTICE

Indicates that an unintended result or situation can occur if the relevant information is not taken into account.

If more than one degree of danger is present, the warning notice representing the highest degree of danger is used. Notice warning of injury to persons with a safety alert symbol may also include a warning relating to equipment damage.

Qualified Personnel

The device described in this documentation may be operated only by **qualified personnel**. Qualified personnel are those who, based on their training and experience, are capable of identifying risks and avoiding potential hazards when working with this device.

Installation, commissioning, use, decommissioning and disposal of this device should be done in accordance with relevant documentation, in particular, its warning notices and safety instructions.

Proper Use of Photoneo Products

Please note the following:

⚠ WARNING

Photoneo products may only be used in accordance with relevant technical documentation. If products and components from other manufacturers are used, these must be recommended or approved by Photoneo. Proper transport, storage, installation, assembly, commissioning, operation, and maintenance are required to ensure that the products operate safely and without any problems. The permissible ambient conditions for storage or operation of the device must be complied with. All information provided in the relevant documentation must be observed.

Preface

Purpose of the Manual

This manual provides information about the installation and set up of the PhoXi 3D Scanner and is designed for engineers, installers, and electricians who possess a general knowledge of automation.

Scope of the Manual

This manual describes the following products:

- Photoneo® PhoXi® 3D Scanner

Trademarks

All names identified by ® are registered trademarks of Photoneo s.r.o. The remaining trademarks in this publication may be trademarks that when used by third parties for their own purposes could violate the rights of the owner.

Table of Contents

Product Overview	6
Laser Device	6
Objects Suitable for Scanning	8
Scope of Delivery	9
Installation	10
Guidelines for Installation	10
Status LEDs	11
Supported Network Topologies	12
Mounting Restrictions	13
Movement During Scanning	13
Strong Electric Field	13
Clearance for Cooling and Wiring	13
Configuration	14
PhoXi Control	14
Hardware Parameters	15
Data Connector	15
Power Connector	16
Power Supply	16
Cables	17
Custom Cables	17
Projection Unit	17
Environmental Conditions	18
Transport	18
Operation	18
Scanning Parameters	19
Datasheet Parameters Explanation	19
Depth Map Resolution	19
Point to Point Distance	19
Calibration Accuracy	20
Temporal Noise	20
Data Acquisition Time	20
Cleaning Instructions	26
Compliance with Standards	27
Declaration of Conformity	27
FCC Rules and Regulations	28
CE	28
Laser Classification	28
Degree of Protection	28
Warranty	29
Dimensions and Illustrations	30
Bottom View: Mounting Plate	30

Bottom View: Detail A	31
Front View: Projection Unit and Camera Unit	32
Changelog	33
Contact Information	34

Product Overview

Photoneo PhoXi 3D Scanner is a device that uses a structured light projection to reconstruct the geometry of a 3D surface of an inspected object. One or more structured patterns are projected onto a scene during scan, which allows calculation of depth from images of the scene. The surface geometry is provided to the user as a depth map or in the form of a point cloud.

The scanning process consists of three phases: capturing (or acquisition), processing (computation) and transfer. In the first stage, the Photoneo PhoXi 3D Scanner projects a series of light patterns onto the scene. Once the data has been acquired, the Scanner calculates all visible points on the surface and sends this data to the user via Ethernet connection.

Communication with the Scanner should be at least 1 Gbps in order to prevent bottlenecks during the data transfer process. To learn more about the scanning process, please consult the PhoXi Control User Guide (see section [PhoXi Control](#)).

Laser Device

⚠ WARNING

This device is a laser product. Do not deliberately look into the laser beam. This may cause injury to the retina. The use of protective eyewear is normally not necessary. The laser class label is present on the back of the device.

The laser projector aperture is located at the right side of the front panel of the device (Figure 1). The aperture is clearly marked with a warning label. Do not look directly into the laser projector while the device is in use.

To avoid unauthorized contact with the Scanner or unintentional viewing of the laser beam, it is recommended to locate the device in a restricted area and take measures to restrict laser light exposure to the surroundings. Although diffuse reflections are not harmful, users should remove mirrors, polished objects, and similar items from the vicinity of the Scanner to avoid specular reflections.

All components of the device, including those sourced from 3rd party suppliers, conform fully with all applicable European directives and regulations.



Figure 1: PhoXi 3D Scanner laser aperture location

The device uses the following labels and warning systems. Apart from the laser aperture label, all are located on the back panel of the device.



Laser radiation hazard warning symbol.



Laser aperture label. Designates the place from which laser radiation is emitted.



Label with manufacturer address, product name, and model, CE and FCC marks, disposal directions and country of origin.

Laser class 3R devices



Laser radiation warning with laser class label. The serial number of the device can be found above the warning labels.

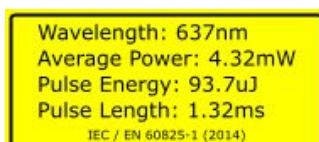

Label specifying wavelength, average power, pulse energy and pulse length of the laser. User on scanner models M, L, XL.

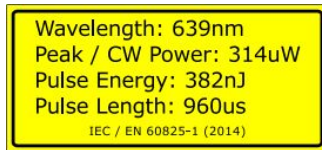

Label specifying wavelength, average power, pulse energy and pulse length of the laser. User on scanner models M, L, XL.

Laser class 2 devices



Laser radiation warning with laser class label. The serial number of the device can be found above the warning labels.



Label specifying wavelength, average power, pulse energy and pulse length of the laser. User on scanner models M, L, XL.

Objects Suitable for Scanning

The PhoXi 3D Scanner uses structured light patterns to acquire 3D data. The scene must be completely still during the scan, free from smoke and particles dispersed in the air. Always bear in mind that the Scanner can only see what you can see with the naked eye and nothing more.

Objects most suitable for scanning are (including and not limited to):

- rough surface objects, for example, wood, rubber, etc.
- objects with a matte finish, such as sand-blasted aluminum, cast iron, etc.
- molded, un-polished plastic materials.

Some objects not suitable for scanning (including and not limited to):

- mirrors and polished metals,
- most liquids (e.g. water, oil),
- moving objects,
- translucent and transparent objects (e.g. glass, transparent plastic),
- some hairy objects (e.g. carpets).

Scope of Delivery

PhoXi 3D Scanner and:

- Power adapter (90-264 VAC/12 VDC, 60 W)
- Power cable
- Ethernet cable adapter (with RJ45 socket)
- L-shaped mounting plate

	Power cable (from scanner to adapter)	Power adapter	Power cable (to power adapter)	Ethernet adapter
Length	3 m	1.6 m	1.8 m	0.5 m



Figure 2: Power cable from scanner to power adapter, power adapter, power cable and ethernet adapter



Figure 3: L-Shaped mounting plate

NOTICE

Software components are needed for the operation of the Scanner. See section [Configuration](#) for more information.

Installation

Guidelines for Installation

PhoXi 3D Scanner has been designed to allow easy installation.

The Scanner can be mounted¹:

- On the supplied L-shaped mounting plate or any other mounting plate of suitable size using 4 M4 screws.
- Using a M8 screw.
- On a tripod using 3/8-16 UNC screw.

To install the Scanner:

1. Mount the Scanner using any preferred method. Refer to Dimensions and Illustrations.
2. When mounting the Scanner, ensure that an appropriate scanning distance is set between the Scanner and the scanned object and eliminate any potential obstacles.

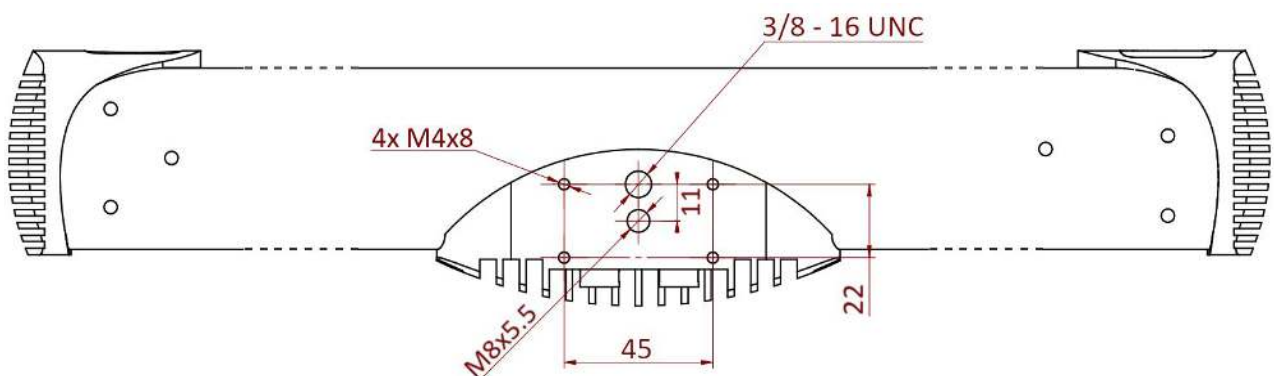

Figure 5: Mounting plate

3. Connect the Scanner to the computer or local network via ethernet cable. See Figure 6 for details.
 - a. Use the supplied ethernet adapter with RJ45 socket.
 - b. Use network cables capable of 1 Gbps or 10 Gbps ethernet (Category Cat5e or better).

¹ A CAD model of the Scanner is available at the Photoneo Wiki: wiki.photoneo.com/index.php/PhoXi_3D_scanners_family#CAD_data

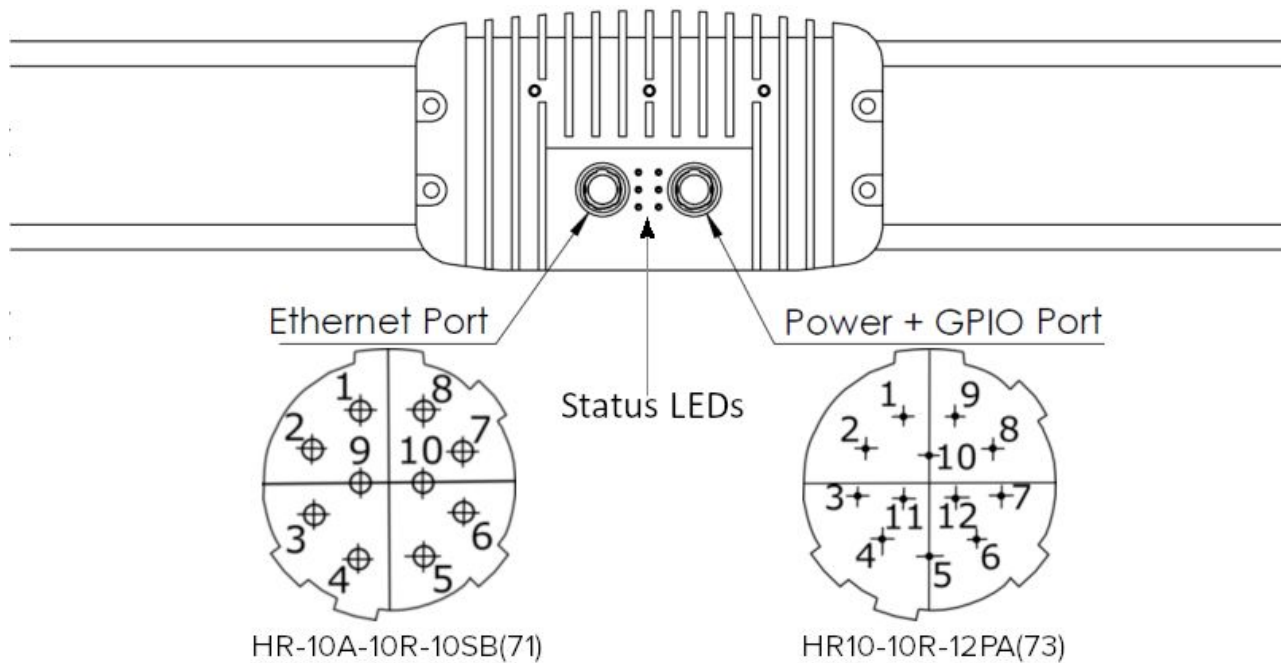

Figure 6: Scanner connectors, ethernet & power port pinout. Refer to sections [Data Connector](#) and [Power Connector](#) for more details

4. Plug the Scanner into the power outlet.
 - a. 12 VDC power supply.
 - b. Use only the supplied power adapter (90-264 VAC / 12 VDC, 60 W).
 - c. The I/O ports are reserved for future use.
5. Download and install the PhoXi Control application from the Photoneo webpage.
6. Run the PhoXi Control application and try to make your first scan. Please refer to the [PhoXi Control User Guide](#).

Status LEDs

As shown in Figure 5, status LEDs are located between the Ethernet port and the Power + GPIO port. The LEDs are grouped into 3 groups of two and from top to bottom have the following statuses:

● Power status
Power cable connected

● Processing unit connected
On → Suitable power connected
Off → Under/overvoltage

● Reserved

● Reserved

● Ethernet speed
Off → Indicates other than 100 Mbps
On → Indicates 100 Mbps

● Ethernet activity
Off → Link is down
On → Link is up and inactive
Flashing Green → Link is up and active

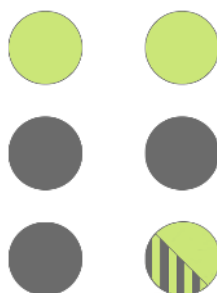

Figure 7: Status LEDs when the Scanner is operating correctly

Supported Network Topologies

The following network topologies are supported by the PhoXi 3D Scanner:

- Direct connection to a computer

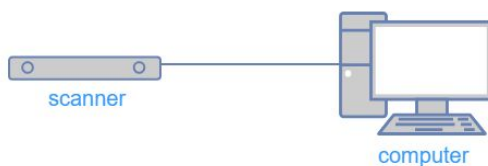

Figure 8: Direct connection

- Scanner connected to a switch

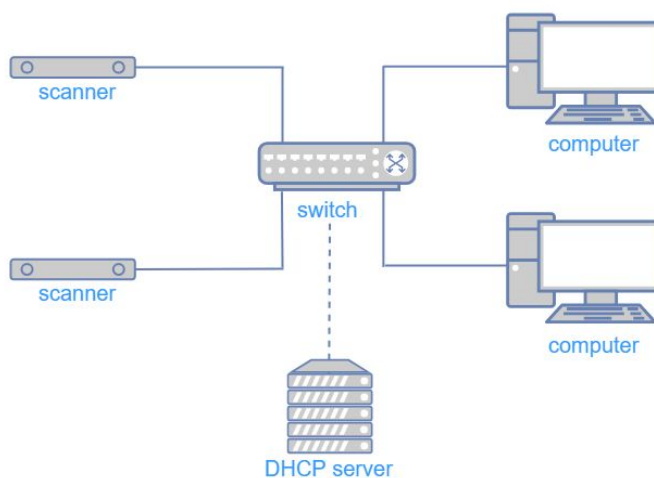

Figure 9: Connected to a switch

The following network topology is not supported by the PhoXi 3D Scanner:

- Scanner connected to a router:



Figure 10: Connecting the Scanner through router is not supported

Note:

- Connecting to the Scanner via WiFi is not recommended as it is slower and less reliable.

NOTICE

If several Scanners are connected to a computer with several ethernet adapters, using static IP addresses on different subnets is recommended.

Mounting Restrictions

Movement During Scanning

NOTICE

It is allowed to mount the scanner on moving constructions or robotic arms. Movement of the Scanner during projection of light patterns causes loss of quality and interferes with depth calculation. Make sure the Scanner is still during acquisition.

If vibrations are present, use damping apparatus to isolate Scanner's mounting from their source. Acceleration and deceleration forces according to Scanner's environment restrictions should be taken into account when mounting of the Scanner is designed.

The maximum acceleration allowed during operation (not including the scanning process) are up to 20 ms^{-2} .

Strong Electric Field

As a general rule, always isolate low-voltage, logic-type devices such as PhoXi 3D Scanner from devices that are high voltage and generate high electrical noise. Carefully consider the routing of the wiring for the devices in the panel as well. Avoid placing low-voltage signal wires and communication cables in the same tray with AC power wiring and high energy, rapidly-switched DC wiring.

Clearance for Cooling and Wiring

PhoXi 3D Scanners are designed to be cooled through natural convection cooling. In order to ensure adequate cooling, a clearance of at least 25 mm above and below the device must be allowed. When planning placement of the PhoXi 3D Scanner, consider placing heat-generating and electronic-type devices in the cooler areas. By reducing exposure to high-temperature environments, you can extend the operating life of the electronic devices considerably.

Configuration

PhoXi Control

PhoXi Control application allows the user to control the PhoXi 3D Scanner manually through graphical user interface or programmatically through the provided API.

The GUI is primarily used to set up the scanning environment, to configure advanced Scanner parameters and to visualize the output. In addition, the GUI can also be used as a powerful debugging tool for development with the API. Calls to the API trigger the same response in the GUI as user inputs. After triggering the scan by calling API method, the application will execute the scan, send it as an output of the call and display it simultaneously in the GUI.

The API serves as a central platform for building custom applications for PhoXi 3D Scanners. In order to facilitate the development process and reduce computing demands all computations are performed on the device itself.

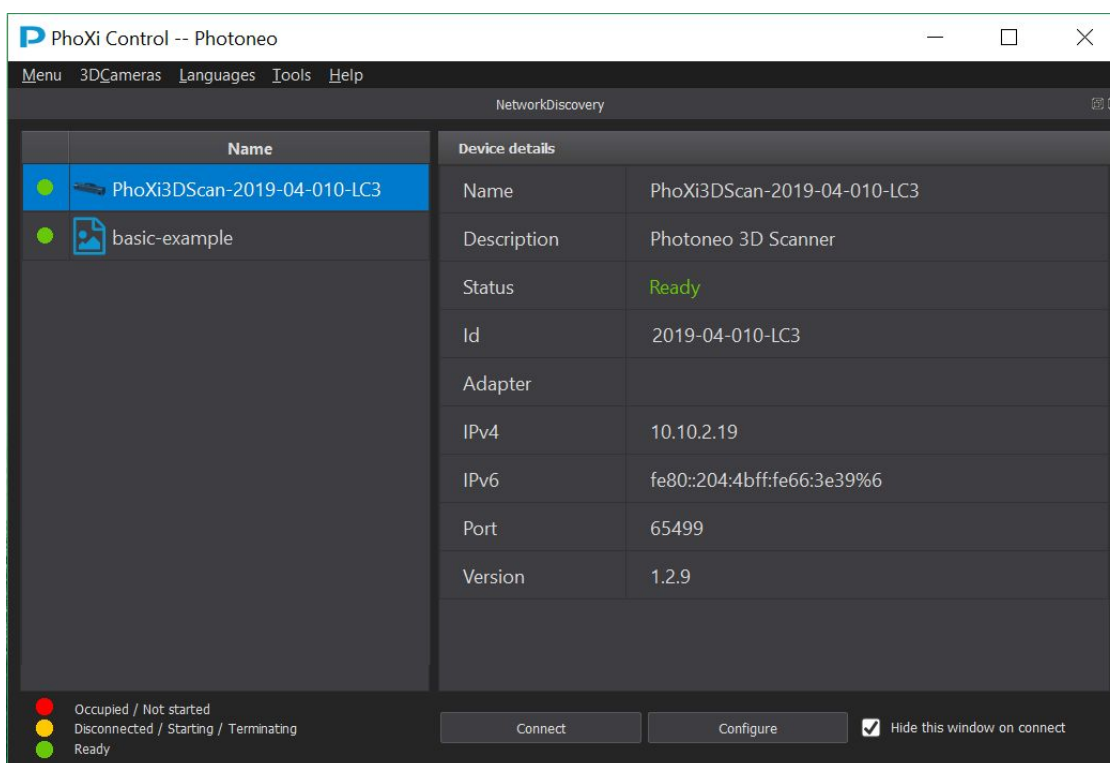

Figure 11: PhoXi Control – Network Discovery

You can download the latest version of PhoXi Control from our website www.photoneo.com/3d-scanning-software/

For more information about the PhoXi Control application, please refer to the [PhoXi Control User Guide](#).

Hardware Parameters

Data Connector

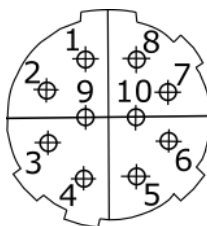

Figure 12: Ethernet pinout, view from the mating side

Connector type: HR10A-10R-10SB(71)

Pin	Cable Color	Pinout
1	White green	MD1_P
2	(+) Red	12V_IN
3	White blue	MD2_N
4	Blue	MD2_P
5	White orange	MD0_P
6	orange	MD0_N
7	White brown	MD3_P
8	(-) Black	GND
9	Green	MD1_N
10	Brown	MD3_N

Power over ethernet (PoE) is not supported.

Power Connector

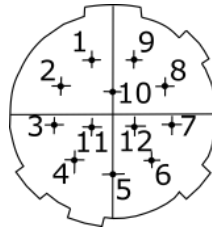

Figure 13: Power + GPIO pinout, view from the mating side

Connector type: HR10-10R-12PA(73)

Pin	Cable Color	Pinout	Function	Note
1	Pink	IN2	*LI: 5 - 12 V	Opto-isolated
2	Dark blue	IN1	-	Opto-isolated
3	Thin black	OUT2	-	Opto-isolated
4	Brown	OUT1	-	Opto-isolated
5	Inner jack	POWER_+12VDC	+ 12 V	-
6	Outer jack	POWER_GND	ground	-
7	Yellow	GPIO1	-	Non-isolated
8	Orange	GPIO3	-	Non-isolated
9	Green	GPIO2	-	Non-isolated
10	Grey / Red	IN_GND	*LI: ground	-
11	White / Light blue	OUT_GND	-	-
12	Purple	GPIO4	-	Non-isolated
-	Thick black	Shielding	-	-

* laser safety interlock: special firmware package and special power cables needed

Power Supply

Operating voltage U_e DC	12 V
Residual ripple maximum (% of U_e)	5 %
Rated operating current I_e (I_{max})	2 A (3 A) <i>Recommended 5 A power supply</i>
Overcurrent protection	Yes
Short circuit protection	Yes (< 1 s, PTC)

Cables

Following cables in **standard** or **industrial** quality are available for additional purchase:

- Ethernet cable
- Power cable (from power adapter to device)

All cables are available in following lengths:

- 3 m, 5 m, 10 m, 15 m

The industrial ethernet cables are sheathed in polyurethane jackets for high flexibility, durability and resistance to chemicals, water and UV.

The industrial power cables are sheathed in flex polyvinyl chloride jackets for high flexibility and resistance to oils, water and UV.

Custom Cables

Connecting the device to power and network by custom cables is allowed. In case custom cables are used, the user has to ensure that correct voltage is reached at the device end. Longer custom cables should have wires of a larger diameter to compensate for voltage losses. Adhere to electrical parameters in the following section when preparing custom cables.

When using custom cables, any damage caused to the device due to incorrect voltage is exempt from warranty.

Powering the device through the ethernet connector (PoE) is not possible.

⚠ CAUTION

Not ensuring correct voltage at the device end can negatively influence the correct functionality of the device or cause permanent damage.

Projection Unit

Projection angle horizontal	47.5° ± 1°	
Projection angle vertical	36.0° ± 2°	
Laser class 3R devices		
Model	XS, S	M, L, XL
Light source	Visible red light (laser)	Visible red light (laser)
Wavelength	639 nm	637 nm
Average power	0.314 mW	4.32 mW
Pulse energy	382 nJ	93.7 µJ
Pulse length	0.96 ms	1.32 ms

Laser class 2 devices		
Model	XS, S	M, L, XL
Light source	N/A	Visible red light (laser)
Wavelength	N/A	637 nm
Peak power	N/A	18.6 mW
Average power	N/A	340 μ W
Pulse energy	N/A	18.6 μ J
Pulse length	N/A	1 ms

Environmental Conditions

Transport

Ambient temperature	From -20 °C to 50 °C (max gradient 10 °C/hour)
Humidity	From 0 % to 95 % non-condensing
Atmospheric pressure	From 1080 hPa to 660 hPa (corresponding to an altitude of -1000 m tp 3500 m)
EN 60068-2-32, Free fall	Consult support@photoneo.com

Operation

Ambient temperature for optimal scanning performance	From 22 °C to 25 °C
Allowed ambient temperature	From 0 °C to 45 °C
Humidity	From 0 % to 95 % non-condensing
Atmospheric pressure	From 1080 hPa to 660 hPa (corresponding to an altitude of -1000 m tp 3500 m)
Maximum acceleration	20 ms ⁻²
EN 60068-2-32, Free fall	Consult support@photoneo.com

Scanning Parameters

Common parameter	Value
Resolution	Up to 3.2 Million 3D points
3D points throughput: Number of 3D points that can be reconstructed in a second in sequential scans)	16 Million points per second
GPU	NVIDIA Maxwell™ 1 TFLOPS with 256 Cores

Datasheet Parameters Explanation

Depth Map Resolution

Maximum number of measured points (the resolution of the camera sensor).

Point to Point Distance

The average distance between two neighboring points in the point cloud of a plane located in the focus distance of the camera. Alternatively, the square of the point size is the average surface sampled by a single 3D point on the plane scanned in the focus distance of the camera.

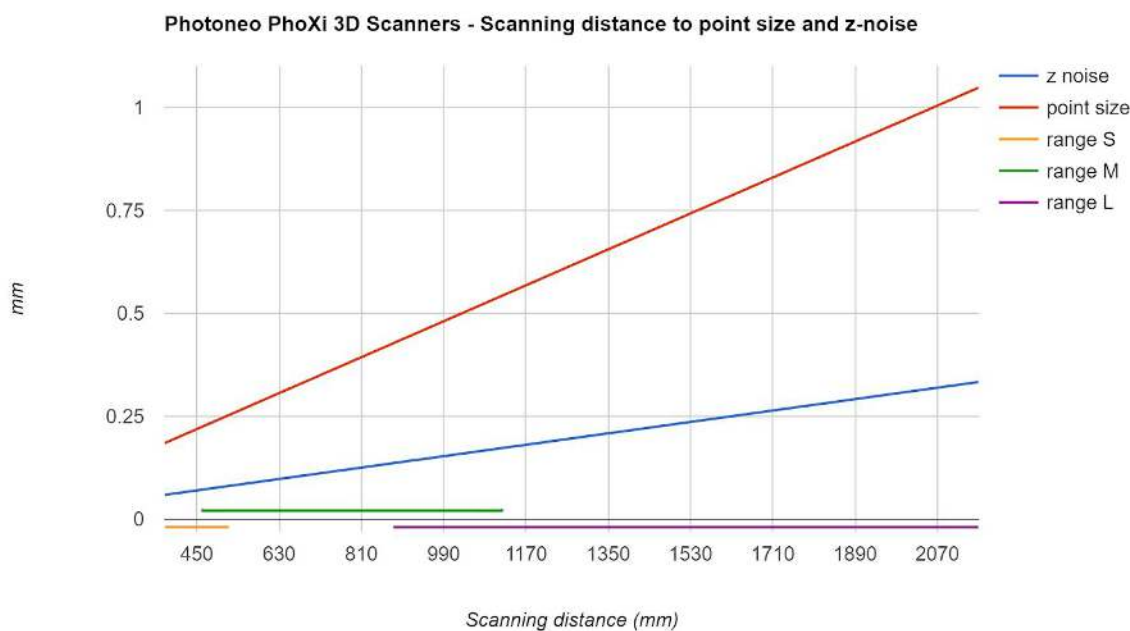

Figure 14: Relationship between scanning distance and point size.

Calibration Accuracy

The accuracy of point measurement as the result of device calibration (can also be understood as space deformation). Every 3D point is determined with a certain measurement error. This measurement error is different for each point across the whole measured volume. Calibration accuracy is standard deviation (σ) of measurement errors of all 3D points.

Temporal Noise

The standard deviation of noise (measured on a diffuse surface with 80 percent albedo). The noise level describes the ability of the sensor to capture local surface details. The noise distribution of our sensor is similar to Gaussian distribution.

Equivalently, temporal noise can also be defined as the average distance of the 3D points from the average Z-value of the 3D points.

Data Acquisition Time

Data acquisition time from shortest possible to maximum estimated in a worst case scenario.

Note:

Values in datasheets are valid in the temperature range 22 °C - 25 °C.

PhoXi 3D Scanner XS - Datasheet

Parameter	Value
Scanning range	161 -205 mm
Optimal scanning distance (focus)	181 mm
Scanning area (at focus distance)	113 x 83 mm
Point to point distance	0.055
Calibration accuracy (1σ)	0.035
Temporal noise (1σ)	0.03
Scanning time	250 - 2000 ms
Dimensions	77 x 68 x 296 mm
Baseline	85 mm
Weight	900 g
Projection angle	73°

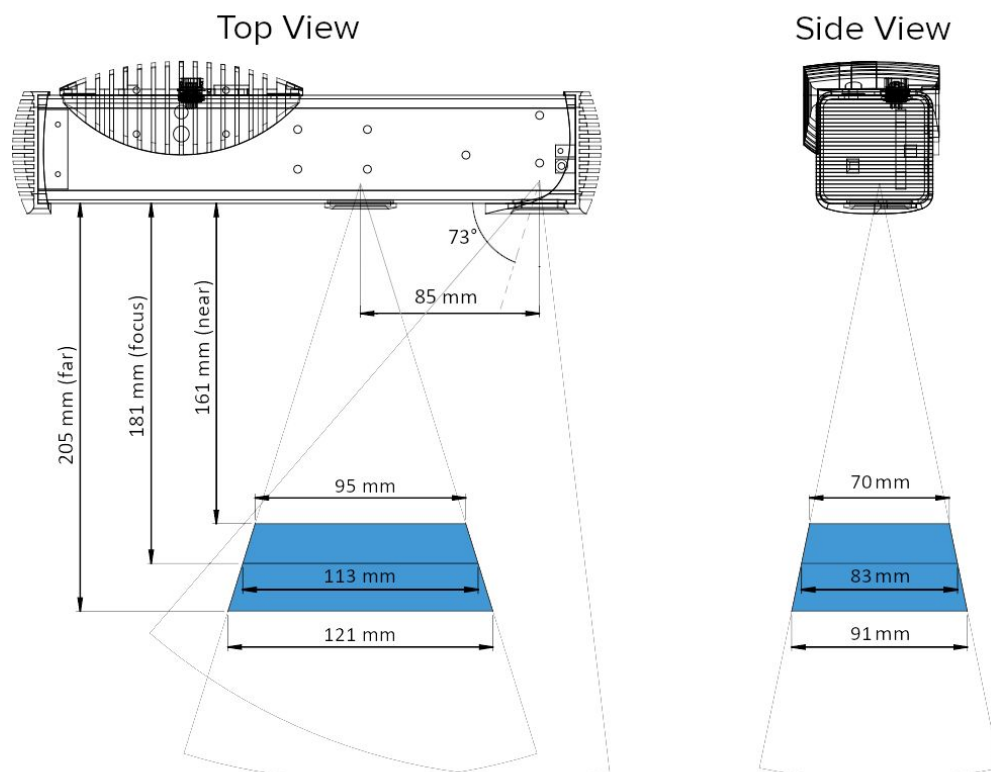

Figure 15: PhoXi 3D Scanner XS scanning range

PhoXi 3D Scanner S - Datasheet

Parameter	Value
Scanning range	384 - 520 mm
Optimal scanning distance (focus)	442 mm
Scanning area (at focus distance)	360 x 286 mm
Point to point distance	0.174
Calibration accuracy (1σ)	0.05
Temporal noise (1σ)	0.05
Scanning time	250 - 2250 ms
Dimensions	77 x 68 x 296 mm
Baseline	230 mm
Weight	900 g
Projection angle	74.55°

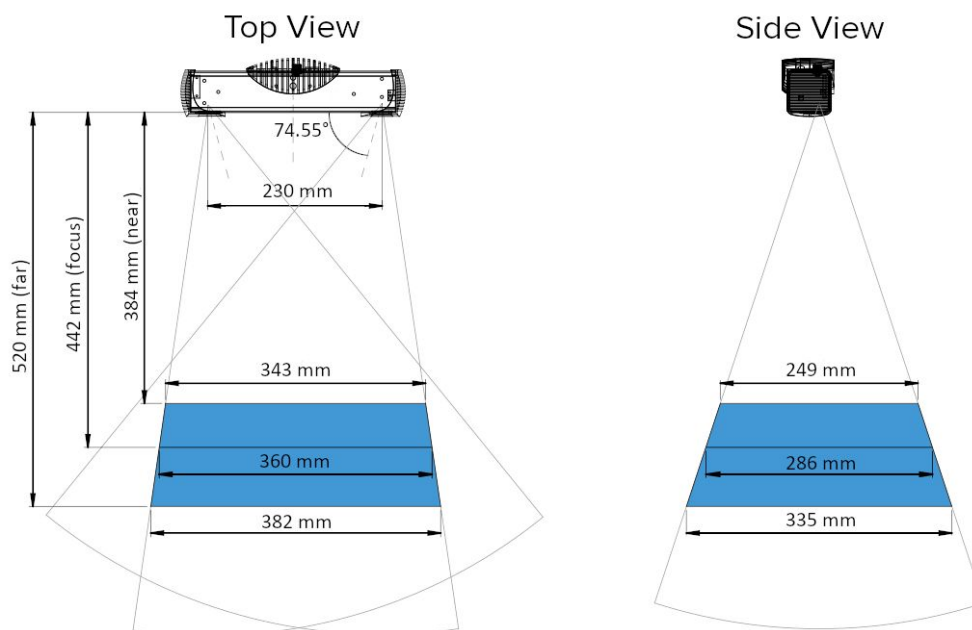

Figure 16: PhoXi 3D Scanner S scanning range

PhoXi 3D Scanner M - Datasheet

Parameter	Value
Scanning range	458 - 1118 mm
Optimal scanning distance (focus)	650 mm
Scanning area (at focus distance)	590 x 421 mm
Point to point distance	0.286
Calibration accuracy (1σ)	0.1
Temporal noise (1σ)	0.1
Scanning time	250 - 2500 ms
Dimensions	77 x 68 x 416 mm
Baseline	350 mm
Weight	950 g
Projection angle	78.25°

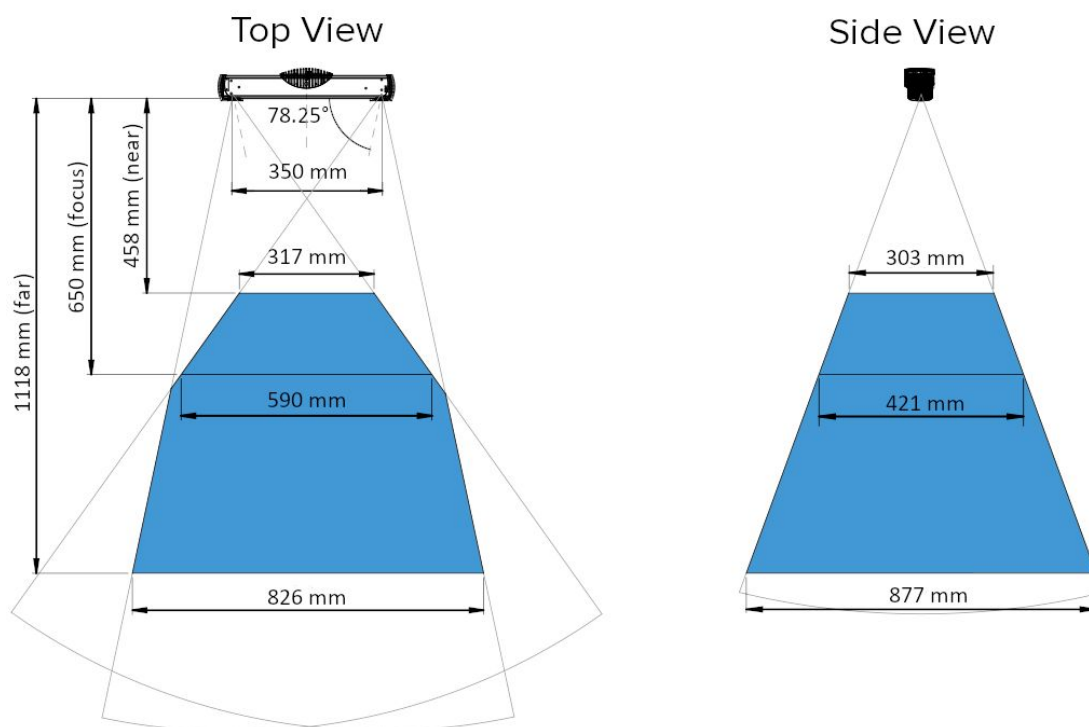

Figure 17: PhoXi 3D Scanner M scanning range

PhoXi 3D Scanner L - Datasheet

Parameter	Value
Scanning range	870 - 2150 mm
Optimal scanning distance (focus)	1239 mm
Scanning area (at focus distance)	1082 x 802 mm
Point to point distance	0.524
Calibration accuracy (1σ)	0.2
Temporal noise (1σ)	0.19
Scanning time	250 - 2750 ms
Dimensions	77 x 68 x 616 mm
Baseline	550 mm
Weight	1100 g
Projection angle	80.55°

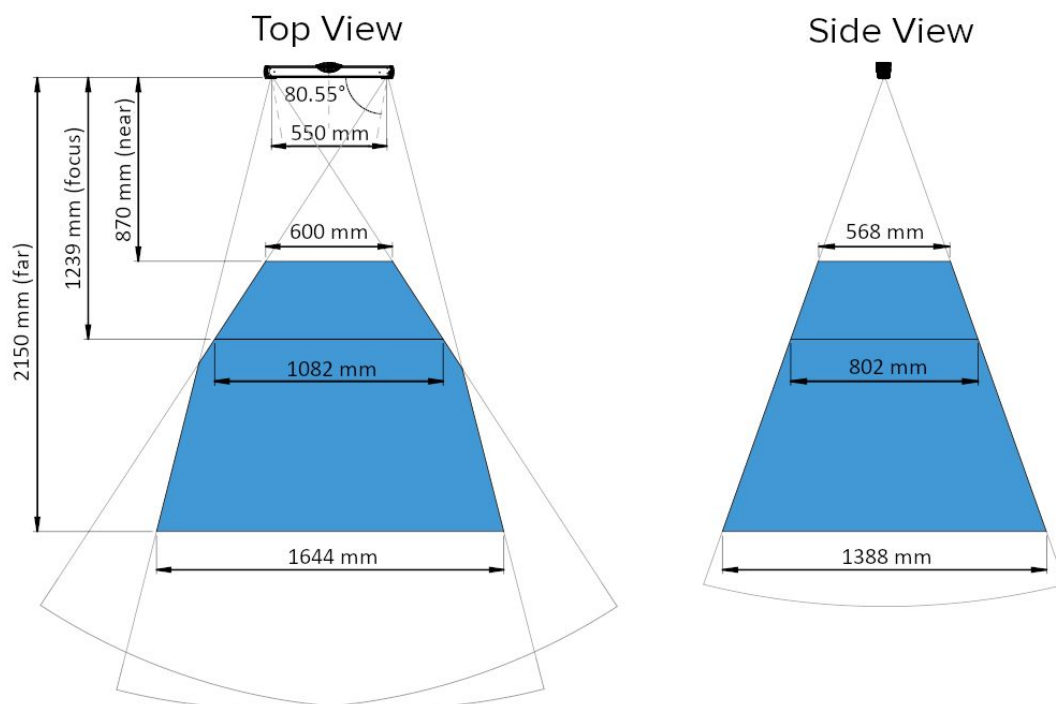

Figure 18: PhoXi 3D Scanner L scanning range

PhoXi 3D Scanner XL - Datasheet

Parameter	Value
Scanning range	1680 mm
Optimal scanning distance (focus)	2326 mm
Scanning area (at focus distance)	1954 x 1509 mm
Point to point distance	0.947
Calibration accuracy (1σ)	0.5
Temporal noise (1σ)	0.4
Scanning time	250 - 3000 ms
Dimensions	77 x 68 x 941 mm
Baseline	850 mm
Weight	1200 g
Projection angle	82.5°

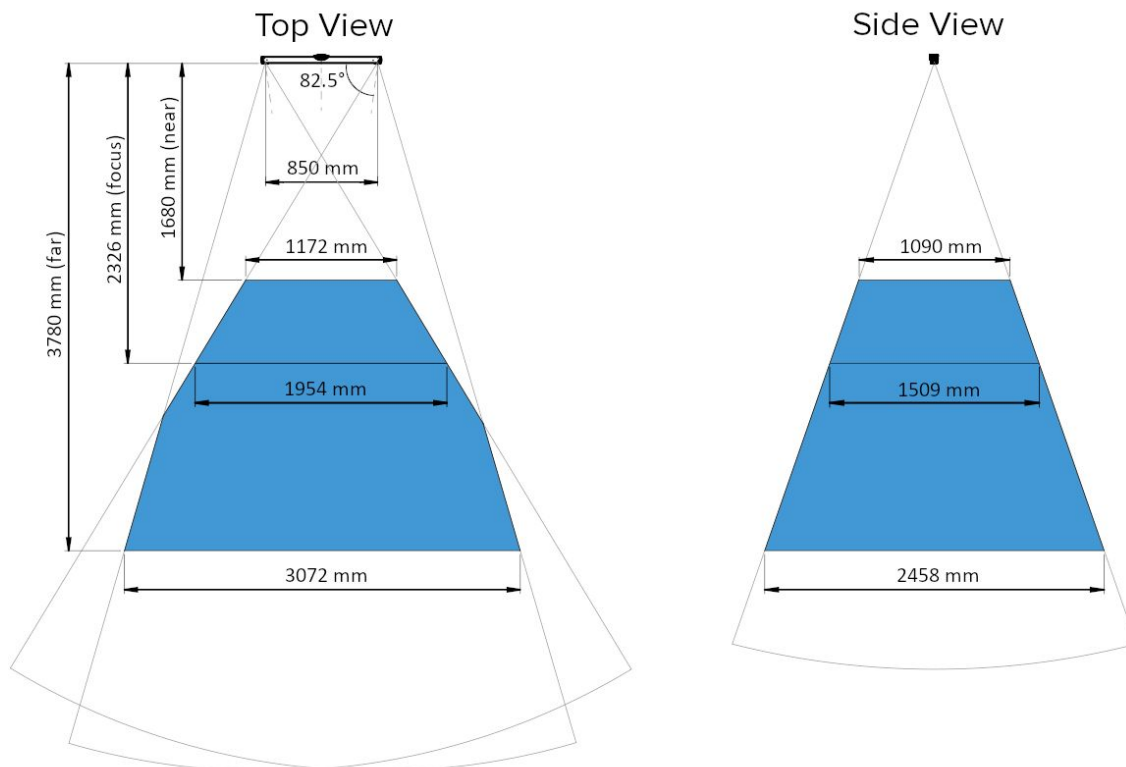

Figure 18: PhoXi 3D ScannerXL scanning range

Cleaning Instructions

PhoXi 3D Scanners are generally low maintenance. To preserve their performance and quality of the scans, please check and maintain their outer optical parts regularly.

The glasses covering the camera unit and the projection should not be touched by bare hands to avoid staining of the glass. This could interfere with light passing through them. If the glass was touched or lightly stained by any other mechanism, wipe the glass with lint free wipes intended for optical components.

In cases where the scanner is used in an environment with lots of dust, especially when the dust contains sharp or hard particles that could potentially damage the glass, clean the glasses with specialized cleaning solution for optical components, eg: First Contact™ Cleaning Solution².

To clean the glasses:

1. Coat the glass with the solution using the applicator. Make sure not to spread it to the edges. The solution immediately dries and creates a film over the glass.
2. Remove the film from the glass using peel tabs with wooden or plastic tips.
3. The film removes any dirt or particles from the glass.

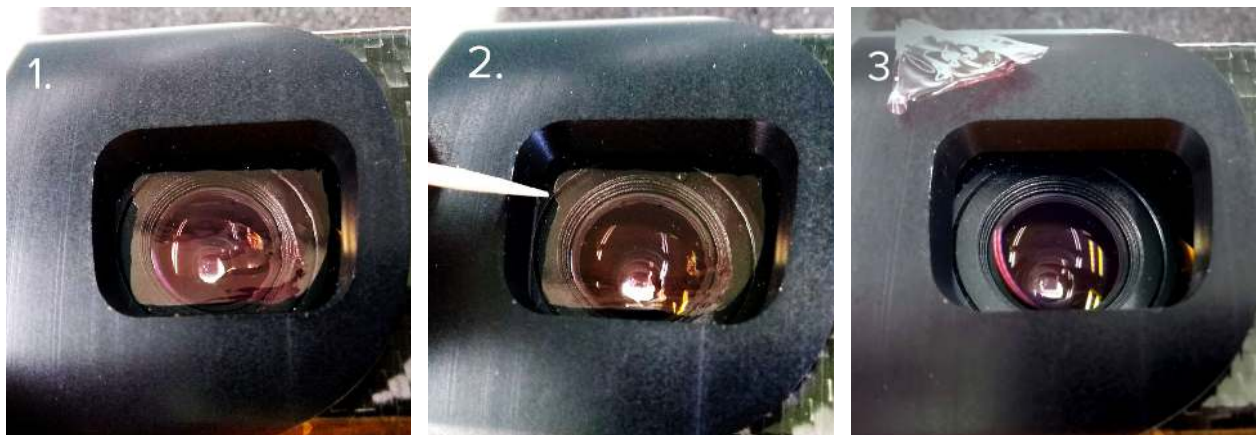

² <http://www.photoniccleaning.com/product-p/fccr.htm>

Compliance with Standards

The PhoXi 3D Scanner conforms with the following standards and test specifications. The test criteria under which were the PhoXi 3D Scanner certified are stated in the standards. Please note that certification status may change without notification. Consult your local Photoneo representative if you need additional information related to the latest listing of exact approvals.

Declaration of Conformity

Declaration of Conformity

with the Directive 2001/95/EC on General Product Safety and the Electromagnetic Compatibility Directive 2014/30/EU

Manufacturer:

Business name: Photoneo s. r. o.
Registered seat: Jamnického 3, Bratislava 841 05, Slovak Republic
Identification number: 47 353 309
Tax ID: 2023884907
EU VAT ID: SK2023884907
Contact: info@photoneo.com, +421 948 766 598

Product (subject of the Declaration):

Photoneo® PhoXi® 3D Scanner

Following the development and testing of the Product throughout 2015 until now, hereby the Manufacturer declares that its Product complies with the requirements and limitations as stated in the Directive 2001/95/EC on General Product Safety and the Electromagnetic Compatibility Directive 2014/30/EU.

The Declaration of Conformity is issued under the sole responsibility of the Manufacturer. It relies on testing provided by 1. Lasermet Limited (Bournemouth, UK), Laser Certification Reports to IEC/EN 60825-1:2014 - No. 1830, 1997b and 1962; 2. Technical Testing Institute in Piestany/ Technicky skusobny ustav Piestany (dedicated Product Certification Body) - Conformity Certificate No. 181299001; 3. Rhein Tech Laboratories, Inc. - FCC Class B DoC Report No. 2017262DOC; 4. Test House of the Faculty of Electrical Engineering and Information Technology, Slovak University of Technology in Bratislava - Test report No. 21/16/SL EMK; and 5. The Manufacturer.

This is a revised version of the Manufacturer's Declaration of Conformity dated 1. 12. 2016.

16. 02. 2018

Authorised Representative / CEO: Mgr. Ján Žižka, Ph.D.

FCC Rules and Regulations



PhoXi 3D Scanner complies with the applicable requirements of FCC Part 2:2016 and FCC Part 15:2016 of the FCC Rules and Regulations and Industry Canada ICES-003. FCC Class B DoC Report No. 2017262DOC compliance report was issued by Rhein Tech Laboratories, Inc.

CE



The PhoXi 3D Scanner satisfies requirements and safety related objectives according to the EC directives listed below. This CE mark is approved by Conformity Certificate No. 181299001; Technical Testing Institute in Piestany.

EC Directive 2014/30/EU Electromagnetic Compatibility

- Electromagnetic emission:
 - EN 61000-6-3:2007/ A1:2011 / AC:2012 Standards for residential, commercial and light-industrial environments
 - EN 61000-3-2:2014 Limits for harmonic current emissions
 - EN 61000-3-3:2013 Limitations of voltage changes, voltage fluctuations and flicker in public low-voltage supply systems, for equipment with rated current
- Electromagnetic susceptibility:
 - EN 61000-6-1:2007 Immunity for residential, commercial and light-industrial environments
 - EN 61000-4-2:2009 Electrostatic discharge immunity test
 - EN 61000-4-3:2006/ A1:2008/ A2:2010/ IS1:2009 Radiated, radio-frequency, electromagnetic field immunity test
 - EN 61000-4-4:2012 Electrical fast transient/burst immunity test
 - EN 61000-4-5:2014 Surge immunity test
 - EN 61000-4-6:2014 Immunity to conducted disturbances, induced by radio frequency fields
 - EN 61000-4-8:2010 Power frequency magnetic field immunity
 - EN 61000-4-11:2004 Voltage dips, short interruptions and voltage variations immunity tests

Laser Classification

Laser class of the scanner is determined according to EN 60825-1:2014 Equipment classification and requirements standard.

PhoXi 3D Scanners are primarily manufactured as laser class 3R devices. Models M, L and XL can be manufactured as laser class 2 devices. The laser class was tested by an independent certification body Lasermet Limited which has issued certification reports No. 1830, 1997b and 1962 for both laser classes.

All devices are labeled according to their respective class following rules given by the harmonized standard.

Details about laser device used can be found in the section [Projection Unit](#).

Degree of Protection

According to standard EN 60529 PhoXi 3D Scanners have the following mechanical protection:

IP40 Mechanical Protection

Protected against solid foreign objects of 1 mm diameter and greater as tested by a standard probe. External protection is required for dust, dirt, water and foreign objects of < 1 mm in diameter.

Warranty

Warranty conditions are stated in General Terms and Conditions on Photoneo website:

<https://photoneo.com/files/manuals/Terms-and-conditions.pdf>

Standard warranty period for the products described in this user manual is **1 year**.

Dimensions and Illustrations

Bottom View: Mounting Plate

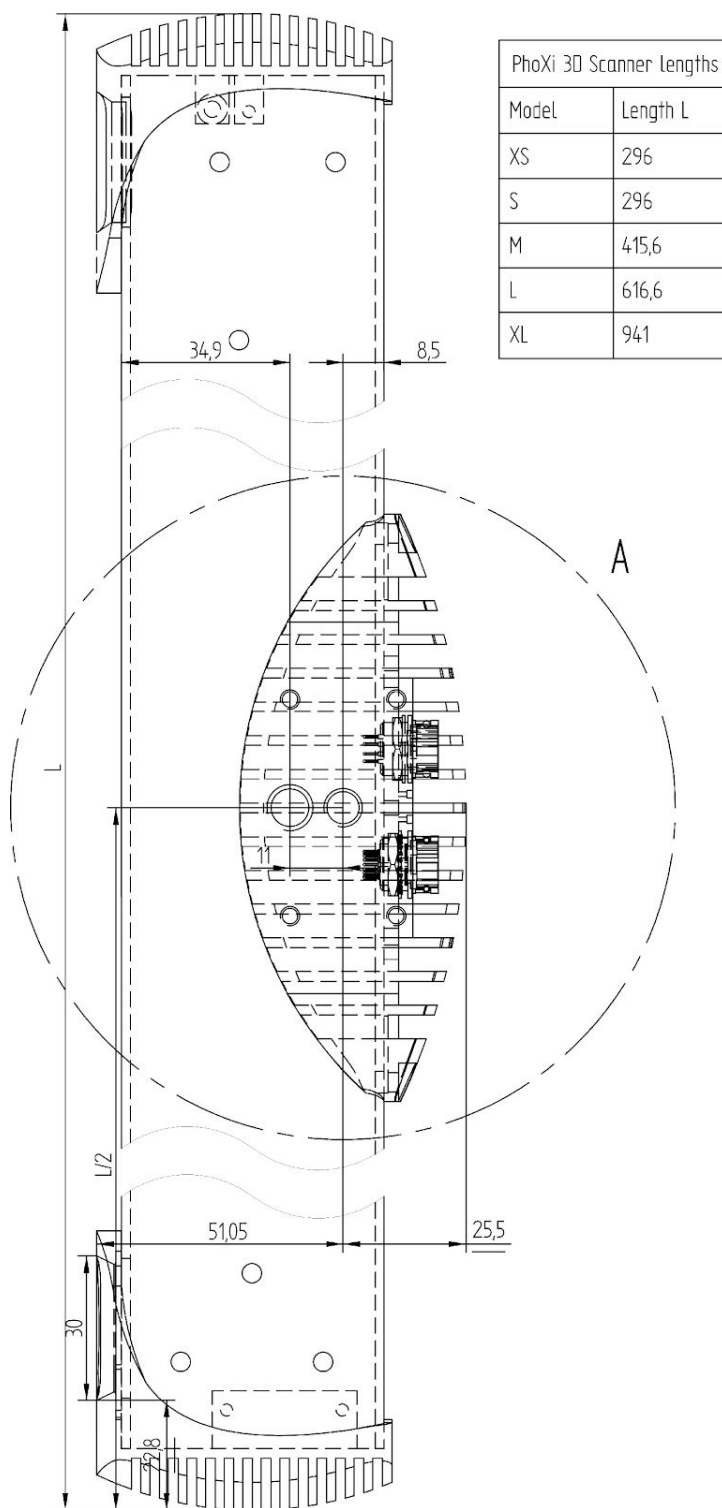

Figure 20: Bottom view of PhoXi 3D Scanner

Bottom View: Detail A

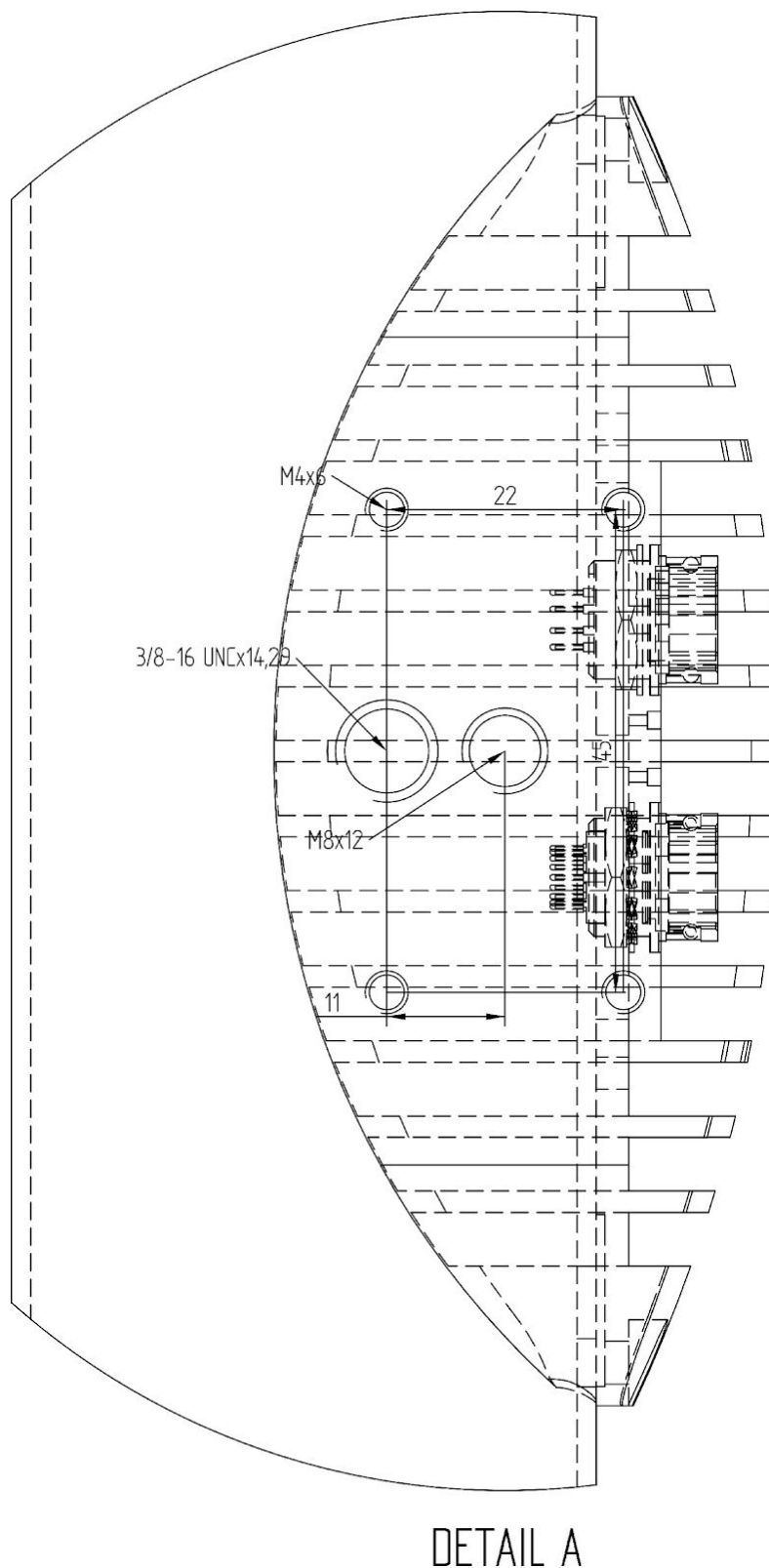

Figure 21: PhoXi 3D Scanner - Detail A

Front View: Projection Unit and Camera Unit

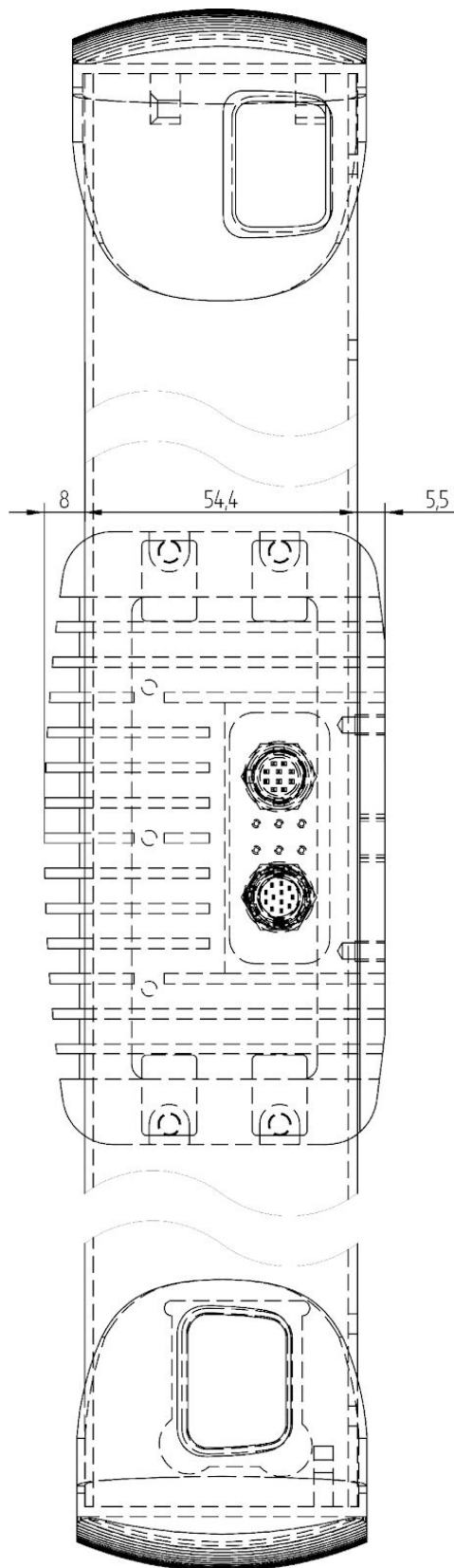

Figure 22: Projection unit and camera of PhoXi 3D Scanner

Changelog

Page	Change
6 - 8	Added section Laser Device : <ul style="list-style-type: none"> ■ Groups information pertaining to laser light <ul style="list-style-type: none"> ▫ Warning labels ▫ Laser class ▫ Safety precautions
9	Updated section Scope of Delivery : <ul style="list-style-type: none"> ■ Added pictures of all hardware components ■ Added cable lengths
10 - 11	Updated section Guidelines for Installation : <ul style="list-style-type: none"> ■ Added descriptive image of mounting plate ■ Updated image of the connectors on the back panel ■ Updated info to use 1 Gbps ethernet cables to connect to the scanner ■ Added warning to use the supplied power adapter
12 - 13	Added section Supported Network Topologies : <ul style="list-style-type: none"> ■ Added info not to use WIFI to connect to the scanner ■ Added info about connecting several scanners to several network adapters on one computer
14	Extended section Configuration
15 - 18	Section Hardware Parameters <ul style="list-style-type: none"> ■ Added complete pinouts for both ethernet and power adapter ■ Added descriptive images of pin orientation ■ Added note that PoE is not supported ■ Added info about made-to-order cables ■ Added info about custom cables ■ Divided parameters more clearly into several tables ■ Moved short circuit protection to electrical parameters ■ Change in temperature ranges for transport and operation ■ Added extended information about projection units of different scanner models
19 - 25	Added section Scanning Parameters : <ul style="list-style-type: none"> ■ Common scanning parameters ■ Datasheet explanation ■ Datasheets for all models ■ Images of scanning volumes of all models
26	Added section Cleaning Instructions
27 - 29	Updated section Compliance with Standards : <ul style="list-style-type: none"> ■ Added Declaration of Conformity ■ Updated list of standards complied with under CE ■ Added information about laser certification ■ Moved degree of protection to this section
29	Added section Warranty

Contact Information

Business name:	Photoneo s. r. o.
Registered seat:	Jamnického 3, 841 05 Bratislava, Slovak Republic
Headquarters:	Plynárenská 1, 821 09 Bratislava, Slovak Republic
Identification number:	47 353 309
Tax ID:	2023884907
EU VAT ID:	SK2023884907
Office contact:	info@photoneo.com , +421 948 766 598
Sales contact:	sales@photoneo.com , +421 948 766 479
Technical support:	support@photoneo.com , +421 948 666 730



| Focused on 3D

Photoneo s.r.o.
Plynárenská 1
82109, Bratislava
Slovakia