



BLUE
LASER

Gocator® 2530

3D SMART LASER LINE PROFILE SENSOR

- UP TO 100 MM FIELD OF VIEW
- 28 MICRONS X RESOLUTION
- 0.5 MICRONS Z REPEATABILITY
- 10,000 PROFILES PER SECOND INCLUDING 3D MEASUREMENT
- SETUP & CONTROL VIA WEB BROWSER OR SDK
- BUILT-IN TOOLS, NO PROGRAMMING
- EXTEND WITH GDK AND GOMAX

Gocator 2530 continues the signature high speed 3D blue laser profiling and compact design of the 2500 series, with a wider field of view. This sensor is ideal for battery and consumer electronics inspection, and applications in rubber & tire scanning and factory automation.

Gocator 2530 line profilers achieve inspection speeds up to 10 kHz, at high resolutions and **fields of view up to 100 mm**. The custom 2 MP high-speed imager, advanced optical design, and blue laser light allow the 2530 to generate excellent 3D data with highly repeatable results on both **shiny and low contrast** surfaces.

INSPECT WITH SPEED AND PRECISION

Take advantage of higher speeds by enabling multiple exposures to measure specular and low contrast surfaces simultaneously (e.g., shiny metal of battery cells, cell phone midplates, rubber). The sensor's speed is also a key advantage in achieving high Y resolution (spacing in direction of travel). Submillimeter X and Z resolutions deliver detailed inspection of small assembly features such as edges or gaps and accurate 3D height measurement of surface geometry and defects (such as scratches and pits).

WIDER FIELD OF VIEW AND LARGER MEASUREMENT RANGE

The 2530's wider field of view allows engineers to scan complete targets with a single sensor (e.g., cell phone midplate). Large field of view and measurement range allow the sensor to handle a wider variety of scan targets.

EASY INTEGRATION INTO TIGHT SPACES AND EXISTING SYSTEMS

The Gocator 2530 has one of the smallest footprints in the industry while maintaining an IP67 rating. This allows the sensor to be mounted in virtually any machine environment.



Gocator® 2530 inspecting battery weld



Tire sidewall uniformity inspection

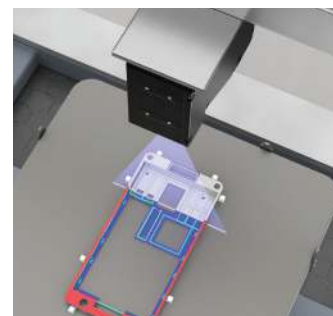

Cell phone midplate inspection

GOCATOR 2530

Data Points / Profile	1920
Resolution X (μm) (Profile Data Interval)	28.0 - 54.0
Repeatability Z (μm)	0.5
Clearance Distance (CD) (mm)	40
Measurement Range (MR) (mm)	80
Field of View (FOV) (mm)	48 - 100
Laser Class	2 (blue, 405 nm)
Dimensions (mm)	46x80x110
Weight (kg)	0.65

ALL 2500 SERIES MODELS

Scan Rate	Up to 10 kHz
Interface	Gigabit Ethernet
Inputs	Differential Encoder, Laser Safety Enable, Trigger
Outputs	2x Digital output, RS-485 Serial (115 kBaud)
Input Voltage (Power)	+24 to +48 VDC (15 Watts); Ripple +/- 10%
Housing	Gasketed aluminum enclosure, IP67
Operating Temperature	0 to 40°C
Storage Temperature	-30 to 70°C
Vibration Resistance	10 to 55 Hz, 1.5 mm double amplitude in X, Y, and Z directions, 2 hours per direction
Shock Resistance	15 g, half sine wave, 11 ms, positive and negative for X, Y, and Z directions
Scanning Software	Browser-based GUI and open source SDK for configuration and real-time 3D visualization. Open source SDK, native drivers, and industrial protocols for integration with user applications, third-party image processing applications, robots, and PLCs.

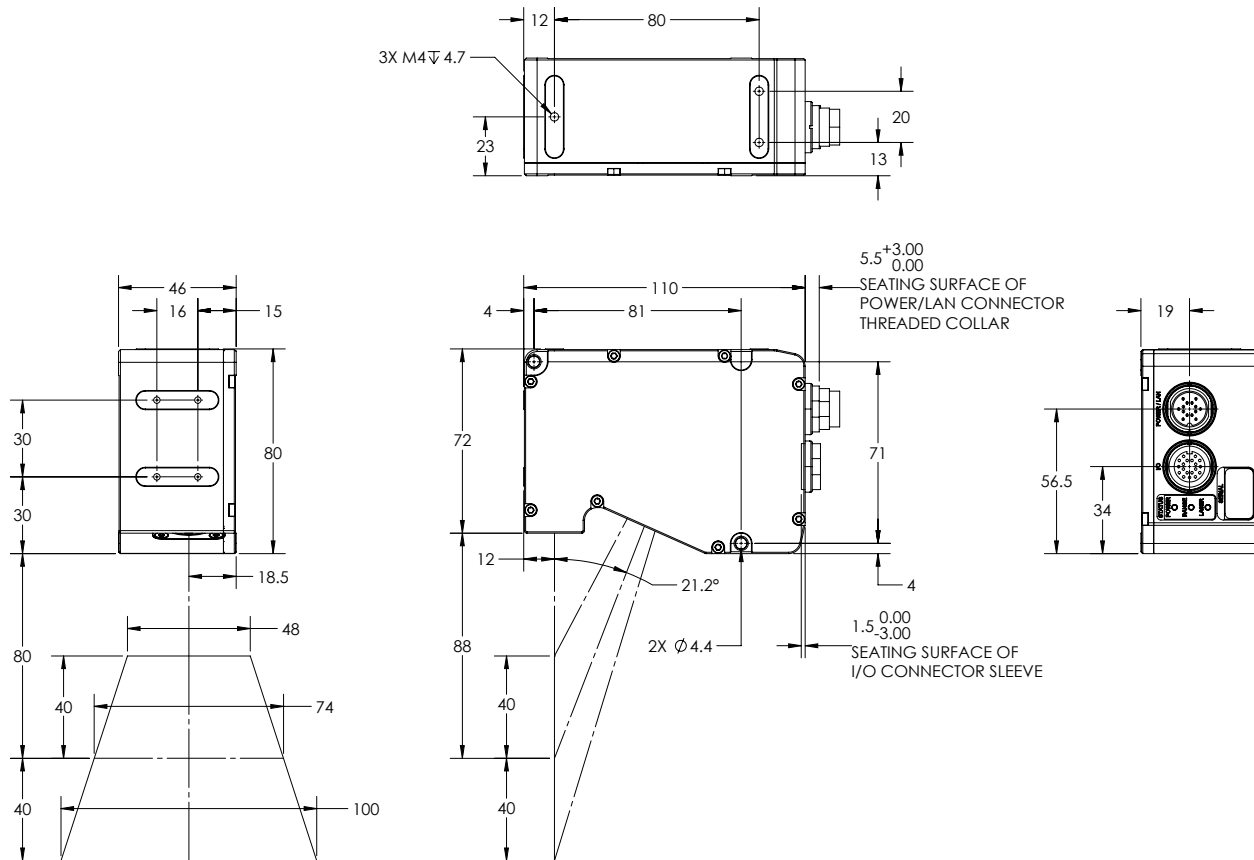

AMERICAS

LMI Technologies Inc.
Burnaby, BC, Canada

EMEAR

LMI Technologies GmbH
Teltow/Berlin, Germany

ASIA PACIFIC

LMI (Shanghai) Trading Co., Ltd.
Shanghai, China



LMI Technologies has sales offices and distributors worldwide. All contact information is listed at lmi3d.com/contact