



## Piranha4 P4-CC-08K050-00-R

Bilinear Color Line Scan CMOS Camera



## Faster, more responsive and in color. The new Piranha4 8k color dual line scan CMOS camera has arrived.

Based on Teledyne DALSA's unique bilinear color line scan CMOS sensor architecture, the new Piranha4 8k camera provides outstanding signal-to-noise for high speed imaging. The P4-8k has 8k resolution with a  $7\ \mu\text{m} \times 7\ \mu\text{m}$  pixel size for optimized optical design. The camera delivers a maximum line rate of 50 kHz.

The choice to use either an ASCII command compliant or an advanced GenICam™ compliant interface makes the camera easier to setup, control, and integrate. Programmability includes exposure control, flat field correction, white balance and color correction, and gain settings.

The Piranha4 8k color camera is ideal for flat panel display, electronics, printed material, solar cell, film, and large format web inspection.

### Key Features

- Color dual line CMOS line scan
- 8k pixel resolution
- Line rates up to 50 kHz
- Exposure control
- 100x antiblooming
- RGB, RG / BG, or G formats
- Camera Link interface
- GenICam or ASCII command compliant interfaces

### Programmability

- Save up to eight sets of correction coefficients
- Adjustable gain and offset
- White balance and color correction
- Lens and shading correction
- Test pattern and diagnostics
- Multi-ROI output allows faster line rates

### Typical Applications

- Flat-panel display inspection
- Printing inspection
- High performance document scanning
- Electronics
- Film inspection
- High throughput applications

### Specifications

Resolution	8192 x 2 pixels
Line Rate	50 kHz Max
Pixel Size	7.04 $\mu\text{m}$ x 7.04 $\mu\text{m}$
Data Format	8 bit
Output	Camera Link
Lens Mount	M72 x 0.75
Responsivity	See graph
Dynamic Range	62 dB
Nominal Gain Range	1x to 10x
Size	80 mm (W) x 80 mm (H) x 57 mm (D)
Mass	700 g
Operating Temp	0 °C to 50 °C, measured at the front plate
Power	Hirose 6-pin male, +12 VDC to +24 VDC
Power Dissipation	16 W
Control & Data	Camera Link
Regulatory Compliance	CE and RoHS
Part Number	P4-CC-08K050-00-R



# Piranha4 P4-CC-08K050-00-R

Bilinear Color Line Scan CMOS Camera

With line rates up to 50 kHz and 8k resolution, this camera inspects and detects with unrivalled precision, speed, and responsivity.

The new Piranha4 camera takes machine vision to the next level.

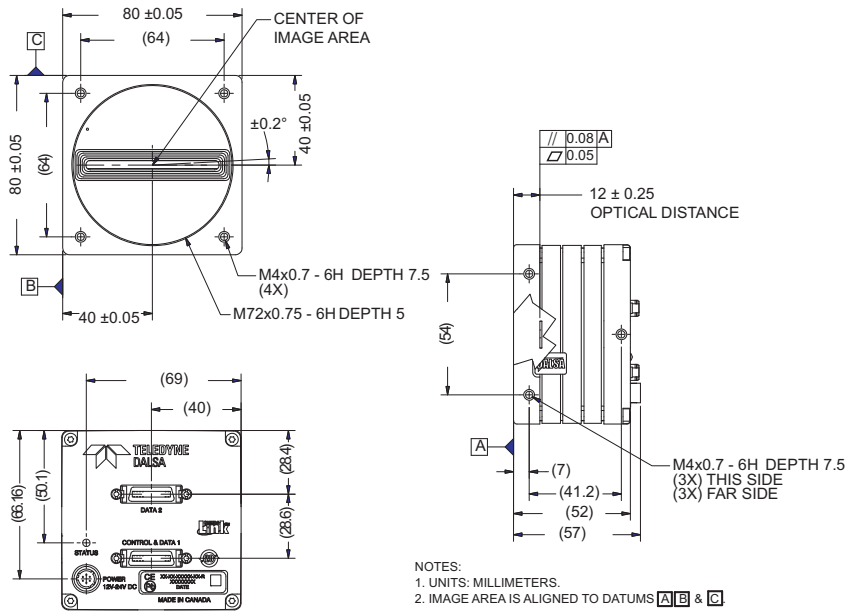
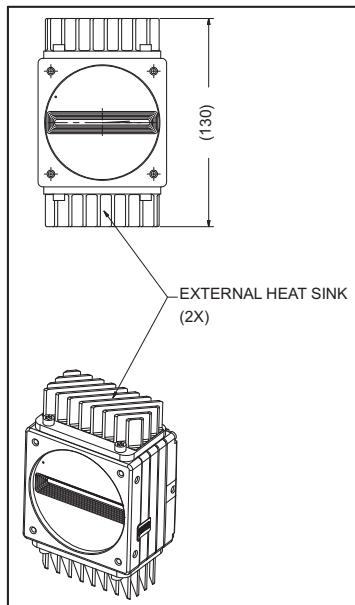
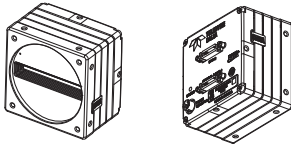
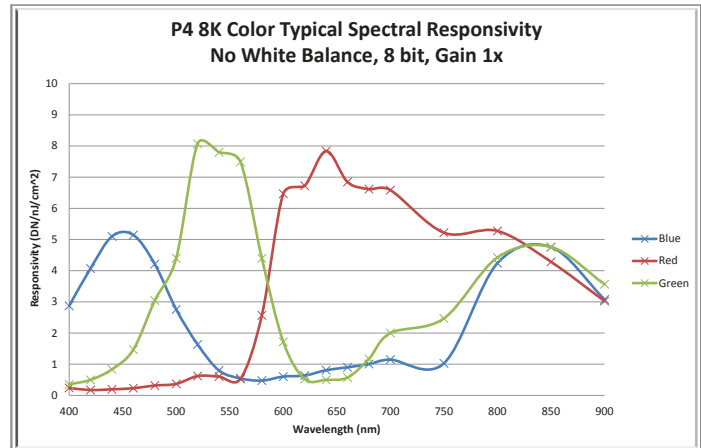

[www.teledynedalsa.com](http://www.teledynedalsa.com)

### Americas

Boston, USA  
+1 978-670-2000  
sales.americas@teledynedalsa.com

### Europe

Krailling, Germany  
+49 89-89-54-57-3-80  
sales.europe@teledynedalsa.com

### Asia Pacific

Tokyo, Japan  
+81 3-5960-6353  
sales.asia@teledynedalsa.com

Shanghai, China  
+86 21-3368-0027  
sales.asia@teledynedalsa.com