



BLUE
LASER

Gocator® 2510/2520

3D SMART LINE PROFILE SENSORS

- PRE-CALIBRATED TO SCAN OUT-OF-THE-BOX
- X RESOLUTION DOWN TO 8 μm
- 10,000 PROFILES PER SECOND INCLUDING 3D MEASUREMENT
- SETUP & CONTROL VIA WEB BROWSER OR SDK
- BUILT-IN TOOLS, NO PROGRAMMING
- EXTEND WITH GDK AND GOMAX

Gocator 2510 and 2520 3D smart sensors are the fastest, most compact, and advanced Gocator laser line profilers to date. Designed for high performance small parts inspection, these line profilers achieve fast scan speeds (up to 10 kHz), and high X resolution (8 μm). With a custom 2MP high-speed imager, advanced optical design, and blue laser light, Gocator 2510 and 2520 generate excellent data with highly repeatable results even on shiny surfaces.

INSPECT WITH SPEED AND PRECISION

See and do more with micron resolution and faster scan rates. Take advantage of the higher speed by enabling multiple exposures to measure high-contrast targets at production speed. With an X resolution down to 8 μm , small features such as edges or gaps can be easily measured.

LARGE FIELD OF VIEW AND MEASUREMENT RANGE

Accomplish more with fewer sensors, while still capturing the finest surface and edge details with a large field of view. A large measurement range lets you handle a wider variety of parts.

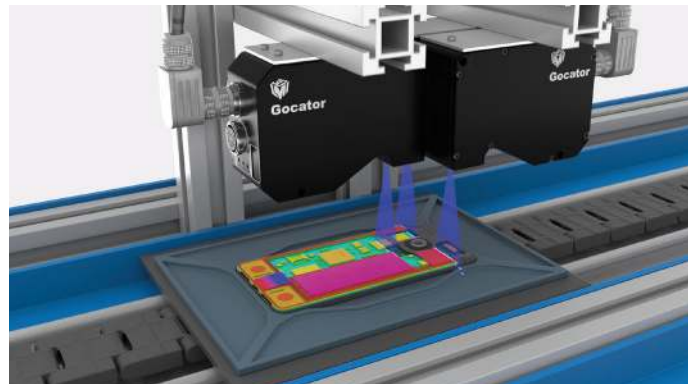

Phone component & frame inspection

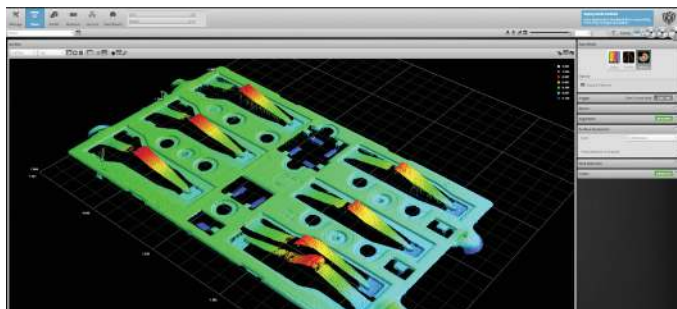

Gocator's browser-based graphical user interface



Phone bezel gap and flushness

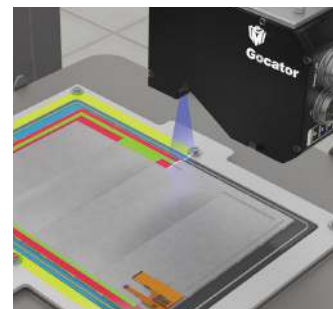

Glue bead inspection

GOCATOR 2500 SERIES MODELS	2510	2520
Data Points / Profile	1920	1920
Resolution X (µm) (Profile Data Interval)	8.0	13.0 - 17.0
Linearity Z (+/- % of MR)	0.015%	0.006%
Repeatability Z (µm)	0.2	0.4
Clearance Distance (CD) (mm)	17.0	47.5
Measurement Range (MR) (mm)	6	25
Field of View (FOV) (mm)	13.0 - 14.5	25 - 32.5
Laser Class	2 (blue, 405 nm)	2 (blue, 405 nm)
Dimensions (mm)	46x80x110	46x80x110
Weight (kg)	0.65	0.65

ALL 2500 SERIES MODELS	
Scan Rate	2.4 kHz (2510 full field of view) / 1.6 kHz (2520 full field of view) to 10 kHz
Interface	Gigabit Ethernet
Inputs	Differential Encoder, Laser Safety Enable, Trigger
Outputs	2x Digital output, RS-485 Serial (115 kBaud)
Input Voltage (Power)	+24 to +48 VDC (15 Watts); Ripple +/- 10%
Housing	Gasketed aluminum enclosure, IP67
Operating Temperature	0 to 40°C
Storage Temperature	-30 to 70°C
Vibration Resistance	10 to 55 Hz, 1.5 mm double amplitude in X, Y, and Z directions, 2 hours per direction
Shock Resistance	15 g, half sine wave, 11 ms, positive and negative for X, Y, and Z directions
Scanning Software	Browser-based GUI and open source SDK for configuration and real-time 3D visualization. Open source SDK, native drivers, and industrial protocols for integration with user applications, third-party image processing applications, robots, and PLCs.

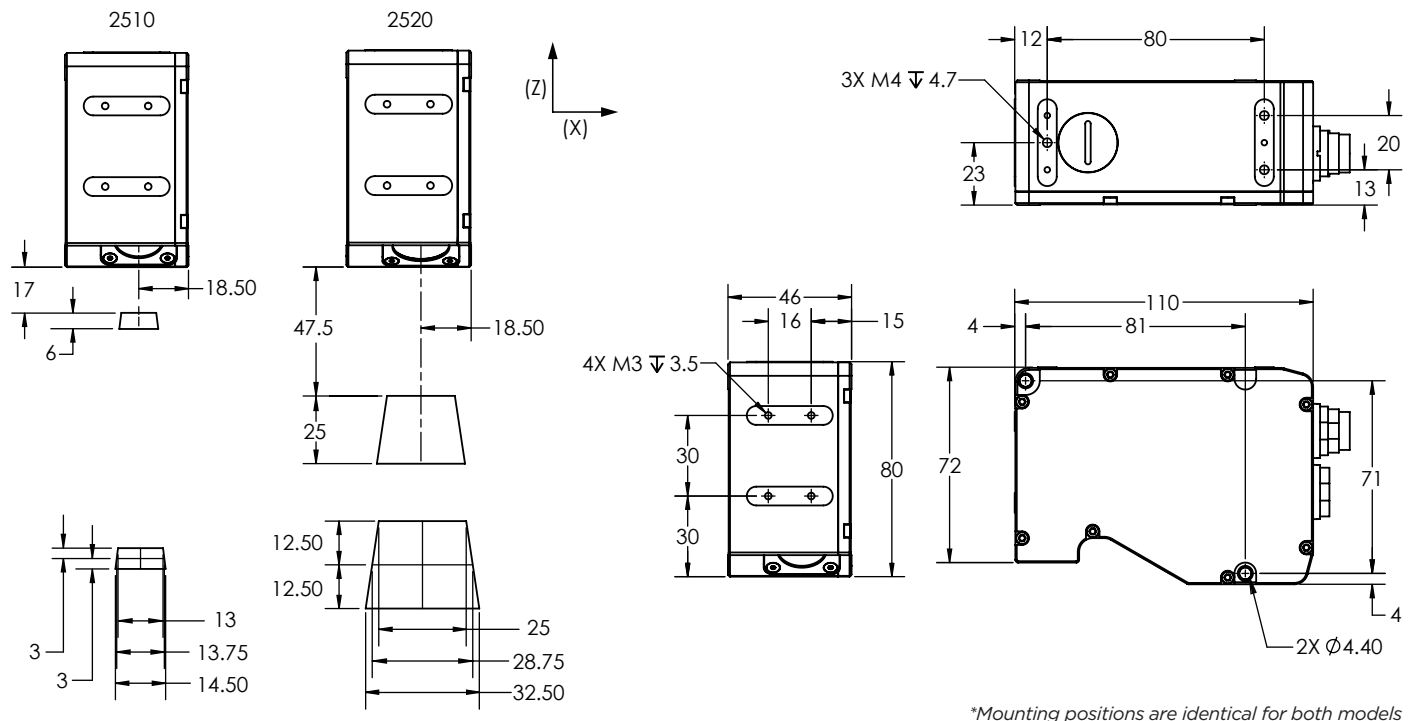

AMERICAS
LMI Technologies Inc.
Burnaby, BC, Canada

EMEAR
LMI Technologies GmbH
Teltow/Berlin, Germany

ASIA PACIFIC
LMI (Shanghai) Trading Co., Ltd.
Shanghai, China



LMI Technologies has sales offices and distributors worldwide. All contact information is listed at lmi3d.com/contact