

Linea™ ML Monochrome

8k and 16k Multiline CMOS Camera



Key Features

- » High speed: up to 300 kHz line rate
- » High dynamic range (72 dB)
- » Bi-directional
- » Independent exposure control per line (start and end of exposure)
- » Long fiber optic cable
- » LUT
- » Low system cost

Programmability

- » Multiple regions and areas of interest
- » Flat field and lens shading correction
- » High speed loading of coefficient sets
- » GenICam™ compliant interface

Typical Applications

- » Flat panel inspection
- » Electronics inspection
- » Web inspection
- » General purpose machine vision

High-Speed Monochrome Camera with a Fiber Optic Interface

The Linea™ ML multiline CMOS 8k and 16k monochrome cameras meet the requirements of demanding imaging applications with industry leading performance. Based on Teledyne DALSA's unique CMOS line scan technology, the Linea ML cameras deliver superb images in HDR with a compact footprint and a high-speed fiber optic interface.

Specifications

Resolution	8,192 x 4 pixels (8k) 16,384 x 4/1 pixels (16k)
Line Rate	300/143 kHz maximum
Pixel Size	5 μm x 5 μm
Data Format	8 or 12 bits, selectable
Output	Monochrome / HDR
Lens Mount	M58 x 0.75 (8k) M90 x 1 (16k)
Responsivity	See graph
Dynamic Range	72 dB
Nominal Gain Range	1x to 10x
Size	76 mm x 76 mm x 85 mm (8k) 97 mm x 140.5 mm x 78.6 mm (16k)
Mass	< 500 g (8k) 1.2 kg (16k)
Operating Temp	0 °C to +65 °C, front plate
Power	+12 V to +24 V DC, Hirose 12-pin
Power Dissipation	15 W (8k) 25/21 W (16k)
Control & Data	Camera Link HS, LC (8k) or CX4/LC (16k)
GPIO	Direction and independent line control
Regulatory Compliance	CE, FCC, and RoHS

Camera Model

Part Number	Resolution	Max. Line Rates	Pixel Size	Output
ML-FM-08K30H-00-R	8,192 x 4 pixels	280 kHz (140 kHz x 2) / 300 kHz using AOI	5 μm x 5 μm	Mono / HDR
ML-HM-16K30H-00-R	16,384 x 4 pixels	300 kHz (150 kHz x 2)	5 μm x 5 μm	Mono / HDR
ML-FM-16K15A-00-R	16,384 x 1 pixels	143 kHz	5 μm x 5 μm	Mono

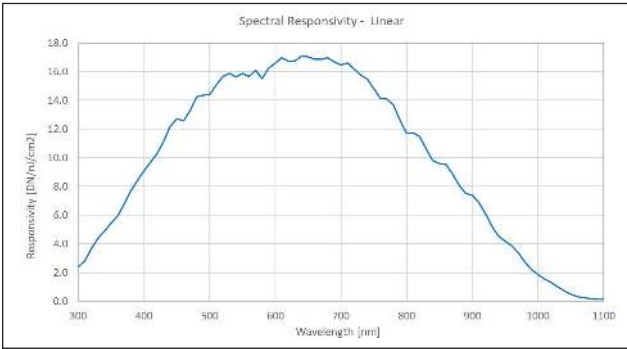

8k Model

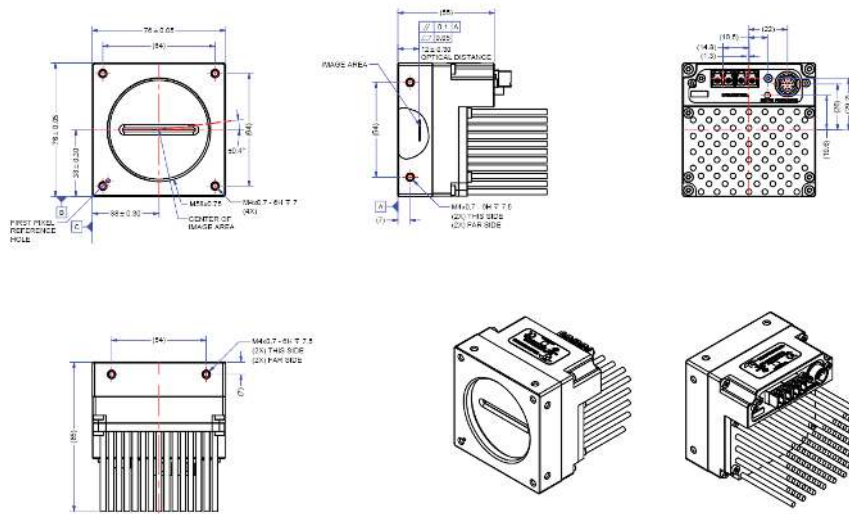

NOTES:
1. UNITS: MILLIMETERS
2. IMAGE AREA IS ALLIGNED TO DATUMS ① ② ③ ④

16k Model

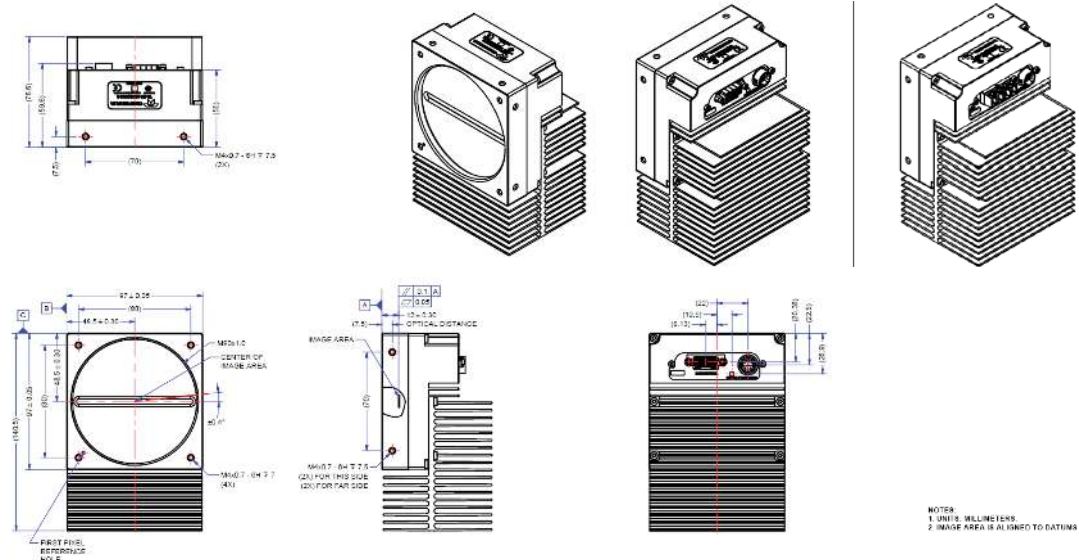

NOTES:
1. UNITS: MILLIMETERS
2. IMAGE AREA IS ALLIGNED TO DATUMS ① ② ③ ④

Americas
Boston, USA
+1 978-670-2000
sales.americas@teledynedalsa.com

Europe
Krailling, Germany
+49 89-89-54-57-3-80
sales.europe@teledynedalsa.com

Asia Pacific
Tokyo, Japan
+81 3-5960-6353
sales.asia@teledynedalsa.com

Shanghai, China
+86 21-3368-0027
sales.asia@teledynedalsa.com